

**FANS**

C162 / C222 / C252 / H162 / H222 / H252

<https://cleanfix.org/instructions-train>

EN: Scan QR code to get instructions in other languages.

DE: QR-Code scannen um Anleitung in weiteren Sprachen zu erhalten.

FR: Scanner le code QR pour obtenir des instructions dans d'autres langues.

IT: Scansione QR-Code per ottenere istruzioni in altre lingue.

ES: Escanea el Código QR para obtener instrucciones en otros idiomas.

PT: Digitalize o Código QR para obter instruções noutras línguas.

TR: Diğer dillerdeki talimatlar için QR kodunu tarayın.

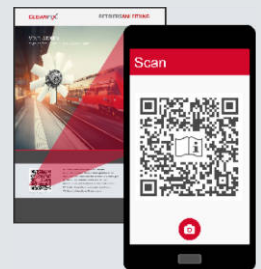

CLEANFIX is revolutionizing engine cooling systems. Our multipatented reversing fans clean radiators, contribute to optimal cooling, and extend the lives of machines in high-dust environments.

CLEANFIX ensures less downtime and helps reduce service costs.

CLEANFIX is used in a wide range of railway vehicles as well as construction, municipal, agricultural, forestry, waste and recycling machines, such as trains, tractors, harvesters, combines, sprayers, excavators, wheel loaders, dozers, skid steers, and a variety of other industrial equipment.

CLEANFIX keeps radiators clean and saves fuel compared to dirty radiators.

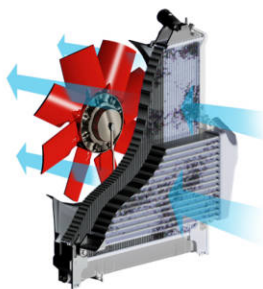

EFFICIENT COOLING

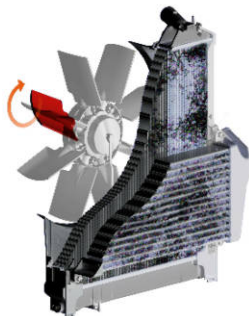

REVERSING OVER THE CROSS POSITION

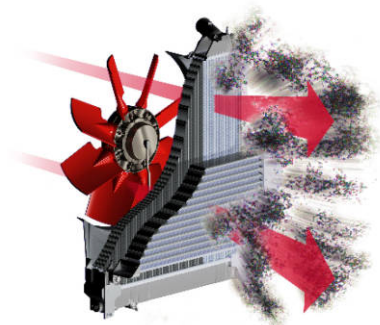

HIGH-PRESSURE



## CONTROL VIA APP

Functions such as radiator cleaning, settings, system check, and many more can be performed easily via the Cleanfix control app.



## FUEL SAVINGS

Cleanfix® reversible fans keep radiators clean and save up to 4 kW compared with dirty radiators.



## LESS DOWNTIME

Cleanfix® reversible fans lengthen the maintenance and cleaning intervals.



## POWERFUL CLEANING

Cleanfix® reversible fans automatically blow dirt out of the radiator at a configurable time interval.



## REDUCED SERVICE COSTS

Cleanfix® changeover fans reduce service costs through less downtime.

## Contents

<b>1</b>	<b>General information</b> .....	<b>5</b>
1.1	Legal notice .....	5
1.1.1	Copyright.....	5
1.1.2	Manufacturer and service address .....	5
1.1.3	Updates .....	5
1.2	Introduction .....	6
1.2.1	Target group.....	6
1.2.2	Liability and damages .....	6
1.2.3	Product identification .....	7
1.2.4	Typographical conventions .....	8
1.2.5	Safety information in the text.....	9
1.3	Product description.....	10
1.3.1	Pneumatic fan components.....	10
1.3.2	Hydraulic fan components .....	11
1.3.3	Cleanfix® electrical components .....	12
<b>2</b>	<b>Safety</b> .....	<b>13</b>
2.1	Intended use.....	13
2.2	Other regulations.....	13
2.3	Safety information.....	14
<b>3</b>	<b>Required tools</b> .....	<b>17</b>
<b>4</b>	<b>Removing the manufacturer's fan</b> .....	<b>18</b>
<b>5</b>	<b>Installing the Cleanfix® reversible fan</b> .....	<b>19</b>
5.1	Mounting the Cleanfix® flange.....	19
5.2	Attaching the pressure hose to the fan.....	21
5.2.1	Pneumatic.....	21
5.2.2	Hydraulic .....	22
5.3	Mounting the Cleanfix® reversible fan.....	24
5.4	Checking the smooth movement of the Cleanfix® reversible fan.....	30
5.4.1	Pneumatic.....	30
5.4.2	Hydraulic .....	32
5.5	Mounting the hydraulic hose fitting (only for H162 fans).....	33
<b>6</b>	<b>Mounting the Cleanfix® electrical components</b> .....	<b>35</b>
6.1	For pneumatic activation.....	37
6.1.1	Cleanfix® valve / for railway vehicles with a compressed air system 37	
6.1.2	Cleanfix® valve unit / for vehicles with a compressed air system.....	41
6.1.3	Cleanfix® control unit.....	45
6.2	For hydraulic activation.....	53
6.2.1	Cleanfix® valve / for vehicles with a hydraulic system .....	53

6.2.2	Cleanfix® valve unit with Mini-Timer or Multi-Timer / for vehicles with a hydraulic system .....	57
<b>7</b>	<b>Setting the timer (push button) .....</b>	<b>61</b>
<b>8</b>	<b>Optional: Operation (Cleanfix control app) .....</b>	<b>63</b>
8.1	Downloading the app.....	64
8.2	Pairing the device .....	65
8.3	Editing the device .....	67
8.4	Performing a system check .....	67
8.5	Performing manual cleaning.....	69
8.6	Turning automatic operation on/off.....	69
8.7	Removing a device.....	70
8.8	Showing the air filter status .....	70
<b>9</b>	<b>Maintenance .....</b>	<b>71</b>
9.1	Servicing the Cleanfix® reversible fan .....	71
9.2	Servicing the Cleanfix® electrical components .....	71
<b>10</b>	<b>Troubleshooting (fans).....</b>	<b>72</b>
10.1	Troubleshooting Cleanfix® pneumatic reversible fans .....	72
10.2	Troubleshooting Cleanfix® hydraulic reversible fans .....	76
<b>11</b>	<b>Troubleshooting (electronic components) .....</b>	<b>78</b>

## 1 General information

### 1.1 Legal notice

#### 1.1.1 Copyright

TRANSLATED OPERATING INSTRUCTIONS

The copyright is owned by Hägele GmbH.

All rights reserved.

The contents of these operating instructions may be changed without notice. Subject to change.

© Hägele GmbH 2023

#### 1.1.2 Manufacturer and service address



Head office in Germany

**Hägele GmbH**

Am Niederfeld 13

DE-73614 Schorndorf  
Germany

Tel.: +49 7181 96988 -36

Fax: +49 7181 96988 -80

E-Mail: [service@cleanfix.org](mailto:service@cleanfix.org)

Website: <http://www.cleanfix.org>

Cleanfix distributors worldwide:

<https://cleanfix.org/en/contact/sales-international>

#### 1.1.3 Updates

The most recent version of the operating instructions and other information are available at <https://cleanfix.org/de/service/anleitung-bahn>.

## 1.2 Introduction

Before installing the Cleanfix kits, familiarize yourself with the contents of these operating instructions.

The operating instructions are a component of the product and must be stored close at hand.

### 1.2.1 Target group

These operating instructions are intended exclusively for mechanics trained on commercial machines.

The product may be installed and started up only by qualified personnel who are familiar with the operating instructions, the product, as well as the national laws and regulations concerning work, safety, and accident prevention.

### 1.2.2 Liability and damages

During installation, it may be necessary to make modifications to the machine. Hägele GmbH does not assume responsibility for modification and installation costs.

Hägele GmbH does not accept any liability for the following:

- direct damages or indirect losses arising from improper operation or maintenance.
- personal injury or property damage caused by untrained personnel or through failure to comply with regulations concerning work, safety, and accident prevention.

The operating instructions contain exemplary illustrations as well as optional features. The product may sometimes differ from the descriptions and depictions.

Check the delivered product for transport damage and completeness before installation:

- Immediately document in writing any defects and damage.
- Photograph damaged parts.
- Send a written damage report to customer service.

As a general principle, unauthorized modifications, alterations, or improper use exempt the manufacturer from liability for resulting damages.

## 1.2.3 Product identification

The following information is required for inquiries to the manufacturer:

### A) Fan serial number

Serial number:

The serial number is found on the side edge of the front housing.

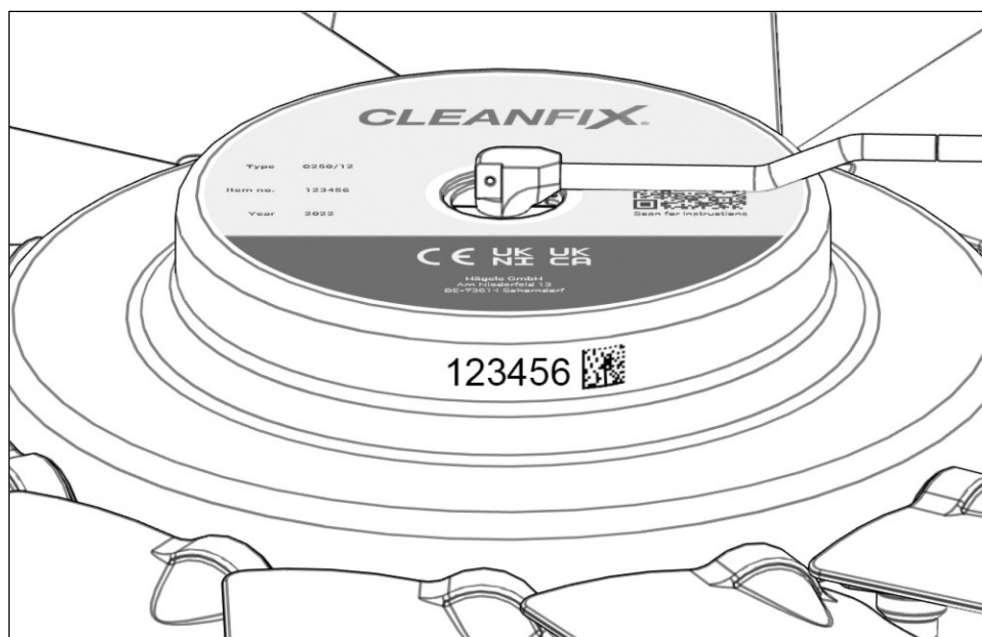

Fig. 1

### B) Machine data

Manufacturer: \_\_\_\_\_

Model: \_\_\_\_\_

Operating hours: \_\_\_\_\_

### C) Photo of the fan

Send in a photo of the fan.

Service address: See section 1.1.2

#### 1.2.4 Typographical conventions

The following symbols and terms are used in these operating instructions:

- Bulleted lists.
- 1) Action to be performed.
  - ➔ Result of the action.
  - Measure to prevent dangers.
- [+]** Optional feature that is not included in the standard features.
- (1) Labeling of a figure.



---

The "Information" pictograph points out tips and additional information.

---



---

The "Additional information" pictograph points out cross-references to information from other documentation.

---



## 1.2.5 Safety information in the text

Safe use is possible only if all information necessary for safe operation is observed.

The safety information warns users about risks and informs them about how to avoid the risks.

General safety information is provided at the beginning of these operating instructions in chapter 2.

Specific warning information appears before a dangerous step.

Safety and warning information that must be followed is highlighted as follows:

### Danger to people



Warns of an extremely dangerous situation in which failure to observe the hazard warning will result in death or major irreversible injury.



Warns of a dangerous situation in which failure to observe the hazard warning may result in death or major irreversible injury.



Warns of a dangerous situation in which failure to observe the hazard warning may result in minor reversible injury.

### Danger to property

#### NOTE

Warns of situations in which failure to observe the information may result in property damage.

In addition, the information and safety rules provided by the manufacturer in the respective vehicle documentation must be observed.

### 1.3 Product description

#### 1.3.1 Pneumatic fan components

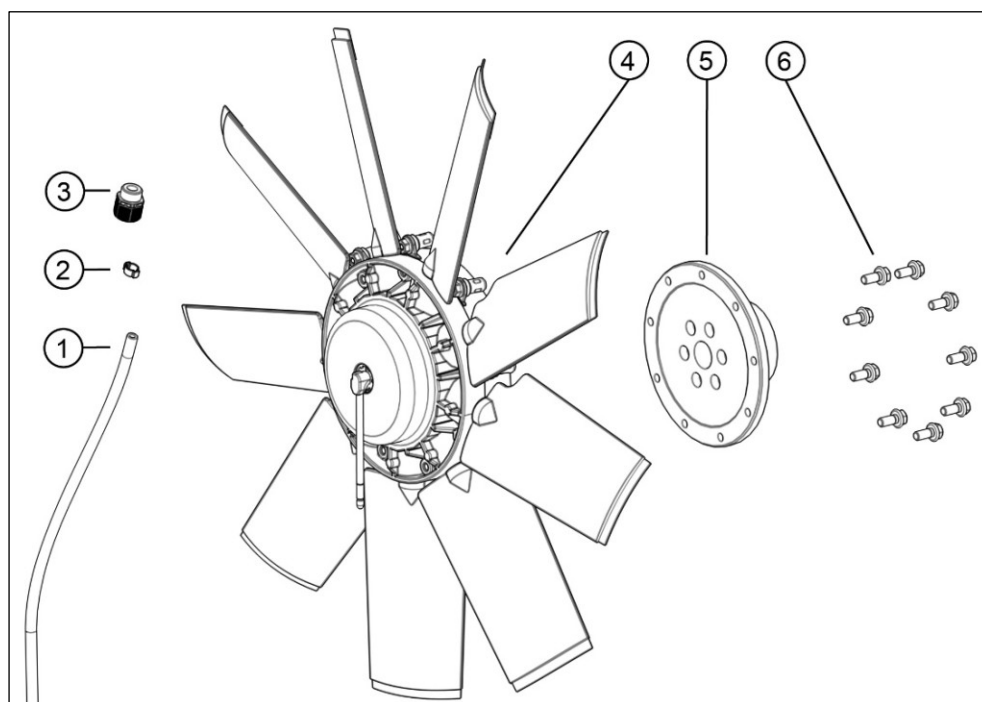

Fig. 2

- (1) Pressure hose
- (2) Hose clamp
- (3) Hose screw connection
- (4) Fan
- (5) Flange
- (6) Flange screws

## 1.3.2 Hydraulic fan components

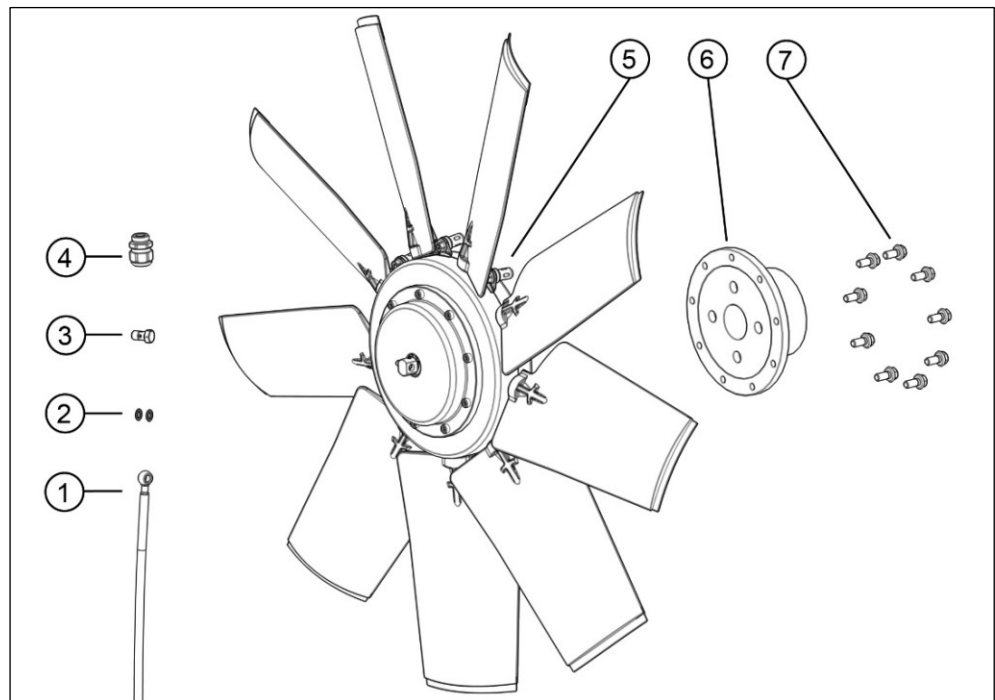

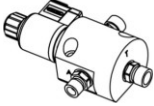
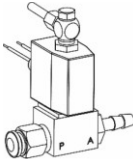
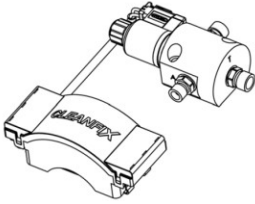
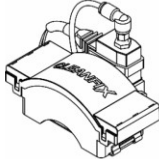
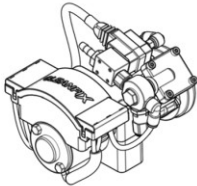

Fig. 3

- (1) Pressure hose
- (2) Usit rings
- (3) Banjo bolt
- (4) Hose screw connection
- (5) Fan
- (6) Flange
- (7) Flange screws

### 1.3.3 Cleanfix® electrical components

Cleanfix® offers a number of control solutions.

The reversing function is activated either pneumatically or hydraulically and controlled electronically.

Reversing function	Hydraulic activation	Pneumatic activation	
	For vehicles with a hydraulic system	For vehicles with a compressed air system	For vehicles without a compressed air system
Press the push button to change from cooling to cleaning. The fan remains in cleaning mode for as long as the push button is pressed.	Valve  Fig. 4	Valve  Fig. 5	
Briefly press the push button to automatically change from cooling to cleaning and back again. Switching from cooling to cleaning and back is time-controlled, for example, every 30 minutes. This interval can be changed as desired. Intermediate cleaning can be performed at any time by pressing the push button.	Mini-Timer valve unit  Fig. 6	Mini-Timer valve unit  Fig. 7	Mini-Timer control unit-  Fig. 8 E-Box  Fig. 9

## 2 Safety

This chapter provides general safety information.

The individual chapters of the operating instructions also contain specific safety information that is not provided in the "Safety" chapter. Safety information should be observed:

- for your own safety.
- for the safety of others.
- to ensure machine safety.

When commercial vehicles are involved, a number of risks can arise due to improper behavior. For this reason, always work very carefully and not under time pressure.

### 2.1 Intended use

The product may be used only for the following purposes:

- For cooling commercial vehicles.
- For cleaning the fans of commercial vehicles

Only persons authorized by the manufacturer may make modifications, alterations, and repairs.

As a general principle, unauthorized modifications, alterations, or improper use exempt the manufacturer from liability for resulting damages.

### 2.2 Other regulations

In addition to these operating instructions, the respective national laws and regulations as amended must be observed (e.g., protective clothing, accident prevention regulations, and occupational health and environmental rules).

## 2.3 Safety information

---

** WARNING!****Modifications to the fan may result in serious injury or death!**

Unauthorized modifications may impair the functioning and/or safety and the service life of the fan. Unauthorized modifications to the fan terminate the manufacturer's warranty and liability. These modifications may result in damage to the machine as well as to serious injury or death.

- Absolutely no modifications may be made to the fan.

---

**Wearing loose-fitting work clothes may result in serious injury or death!**

Loose-fitting clothes can become entangled in rotating parts.

- Wear work and protective clothing stipulated by the employer's liability insurance association.

---

**Working on a machine while it is running may result in serious injury or death!**

No work may be performed on the machine while it is running. Objects or persons may be caught, pulled in, or crushed.

- Work only on machines that have been turned off.
-

**⚠ CAUTION!****Failure to resolve malfunctions may result in accidents or damage!**

Operation of a defective fan or fan component may lead to accidents or damage.

- Immediately stop the machine.
- Shut down the machine.
- Secure the machine.
- Resolve the fault promptly or engage a vehicle shop.

**Activation of the reversing function while persons are standing in front of the vehicle may result in accidents!**

The fan generates strong air currents when it is in the cleaning position. Persons standing in front of the vehicle may be struck by flying dirt when the reversing function is activated.

- Nobody may be standing in front of the vehicle when the reversing function is activated.

**Activation of the reversing function in train stations may result in accidents!**

The fan generates strong air currents when it is in the cleaning position. In closed spaces, this may generate dust and result in damage or accidents due to flying parts.

- Use the reversing function only in a safe location and only outside of closed spaces.

**Parts under pressure may cause injuries!**

Injuries may occur during work on pneumatic and hydraulic parts.

- Only qualified personnel may perform work on parts under pressure.

**Noise may cause injuries!**

When work is performed in the immediate vicinity of the fan, the noise level may exceed 85 dB. This may lead to hearing loss.

- Wear ear protection.

**NOTE**

---

**Reversing the fan while the vehicle is in the red temperature range may result in property damage!**

The cooling effect is interrupted when the reversing function is activated. Reversing the fan while the vehicle is in the red temperature range causes the engine to overheat.

- Do not reverse the fan when it is in the red temperature range.
- Park the vehicle and open the hood so that the vehicle can cool down.

---

**Aging of the hydraulic hose lines may cause damage!**

Hydraulic hose lines are subject to natural aging that reduces the material's performance.

- For normal requirements, the recommended replacement interval is six years (see German Social Accident Insurance (DGUV) Rule 113-020 / as of 2022).

---

**Moist compressed air may cause damage!**

If compressed air is moist, water enters the pneumatic system and may damage mechanical parts such as the piston.

- Use only dry compressed air.
  - If necessary, install a water separator.
- 

The individual chapters of the operating instructions contain further safety information that must also be observed.



### 3 Required tools

#### Flange mounting

- Magnetic or clamp type dial gauge
- 12 Nm - 20 Nm torque wrench

#### Pneumatic pressure hose mounting

- Lubricant
- Pincers (hose clamp pincers) for hose clamp
- Standard tools for pressure hose fitting

#### Hydraulic pressure hose fitting mounting (H162)

- Lubricant
- 10 mm wrench
- 12 mm wrench

#### Fan installation

- Electric drill
- 16 mm and 20 mm drill bits
- 12 Nm - 20 Nm torque wrench
- Locking pliers (for example, vise grip) for clamping the pressure hose
- Standard tools

#### Electrical component mounting and connection

- Electric drill
- 22 mm drill bit
- Standard electrical and hand tools

#### Pressure hose mounting and connection

- Lubricant
- Pincers (hose clamp pincers) for hose clamp
- Standard tools for pressure hose fitting

## 4 Removing the manufacturer's fan

**CAUTION!****Risk of injury due to a hot engine!**

A hot engine can burn hands or other body parts

- Turn off the engine.
- Allow the engine to cool down.
- Remove the ignition key.
- Disconnect the battery.

- 1) Make sure that the engine is turned off.
- 2) If necessary, remove the fan guard and safety components to gain access to the manufacturer's installed fan.
- 3) Loosen any belts that drive the manufacturer's fan pulley.
- 4) Remove the manufacturer's fan.
- 5) Remove other fan accessories as required.



Read and observe the manufacturer's vehicle manual before removing the manufacturer's fan.

## 5 Installing the Cleanfix® reversible fan

### 5.1 Mounting the Cleanfix® flange

- 1) Remove all dirt and rust from the fan drive mounting surface for the flange.
- 2) Loosen any belts that drive the fan pulley.
  - ➔ This ensures a more accurate axial and radial circular runout measurement.
- 3) Remove the label from the flange.
- 4) Clean the surface for the flange.

#### WARNING!

**Using screws of the wrong length may cause property damage!**

If the fastening screws are too short, the flange with the fan may come loose during operation.

- Use longer screws.

**If the fastening screws are too long, the screws or the objects behind them may be damaged.**

- Shorten screws to the correct length.

- 
- 5) Attach the flange to the fan drive using the supplied or suitable screws.



Observe the vehicle manufacturer's indicated torque values (see vehicle manufacturer's manual).



If necessary, insert the fan in the shroud before mounting the flange. If the flange is mounted beforehand, there may not be sufficient space to install the fan in the shroud.

---

**⚠ WARNING!****Axial and radial circular runout may cause property damage!**

Imbalances damage the fan and may result in vehicle damage and serious injury.

- The axial and radial circular runout must be checked using a dial gauge and must not exceed 0.1 mm (0.004").
- Check the fan drive mounting surface and the flange for contamination and clean as necessary.
- If necessary, rotate the flange to the next hole and mount and measure again.

6) Check the axial and radial circular runout using a dial gauge.

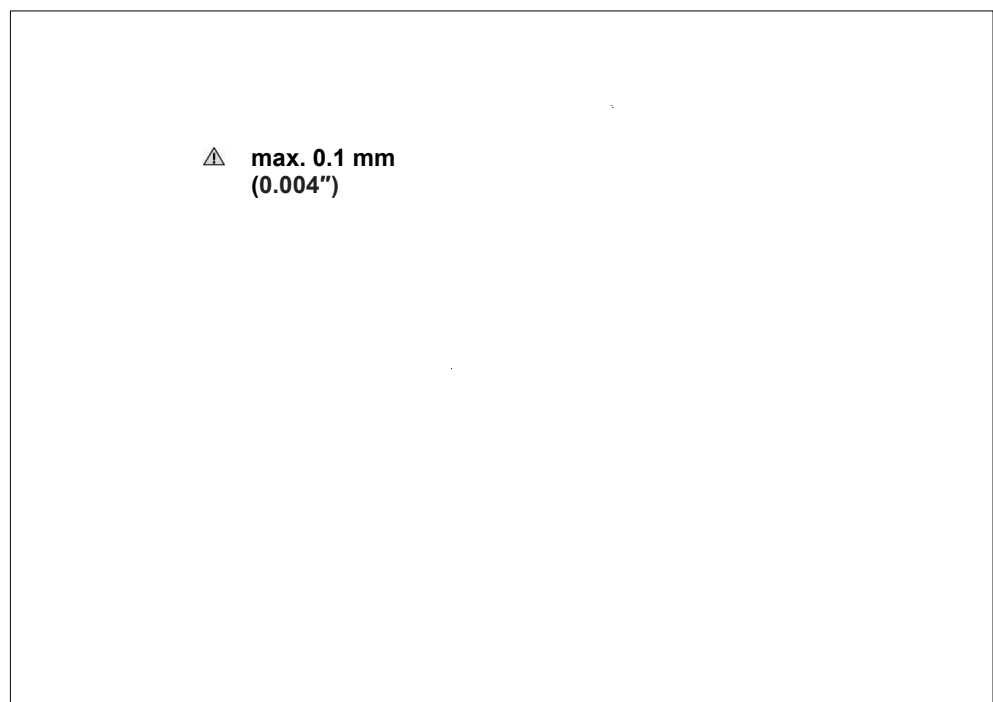

Fig. 10

5.2 Attaching the pressure hose to the fan

5.2.1 Pneumatic

**NOTE**

**Bending the air intake tube may cause property damage!**

The bending radius of the high-pressure hose must be at least 50 mm!

During mounting, the air intake tube can become bent toward the blades. As a result, the blades may graze and damage the hose during operation.

- Carefully bend the air intake tube of the air intake assembly manually back into the original position.

- 1) Apply a thin layer of lubricant to the end of the air intake tube.
  - ➔ This makes it easier to push the pressure hose over the air intake tube.
- 2) Slide the hose clamp over the pressure hose.
- 3) Slide the pressure hose 25 mm over the air intake tube of the air intake assembly up to the side marks.

**! WARNING!**

**An incorrectly mounted hose clamp may cause collision!**

The hose clamp must be parallel to the fan as shown in Fig. 12.

If the ears of the hose clamp point up and down, the blades can collide with the hose clamp during operation.

- Use pincers to rotate the hose clamp into the correct position.

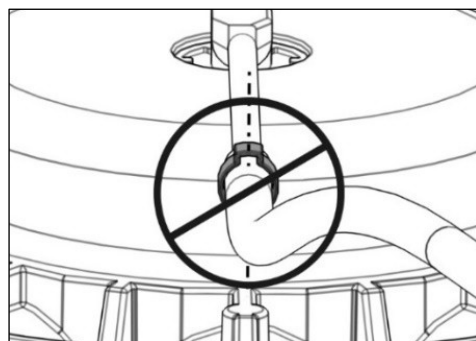

Fig. 11

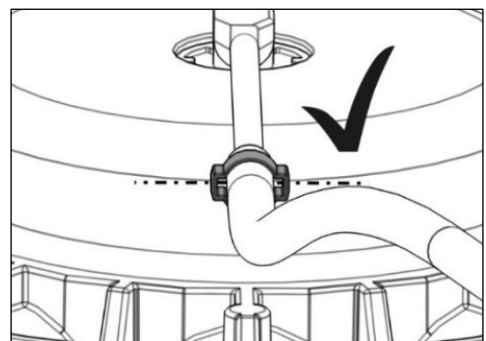

Fig. 12

- 4) Position the hose clamp as shown in Fig. 13.
- 5) Pinch the ears of the hose clamp together with pincers.  
➔ This secures the pressure hose.

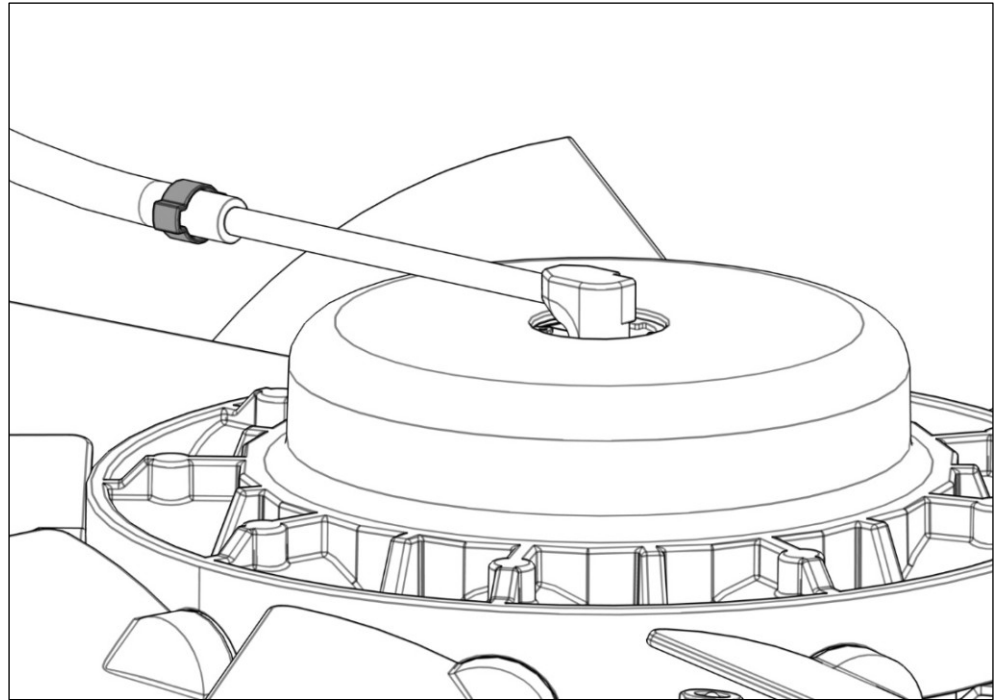

Fig. 13

### 5.2.2 Hydraulic

- 1) Screw the banjo bolt together with the pressure hose and two Usit rings hand-tight in the air intake assembly on the fan.

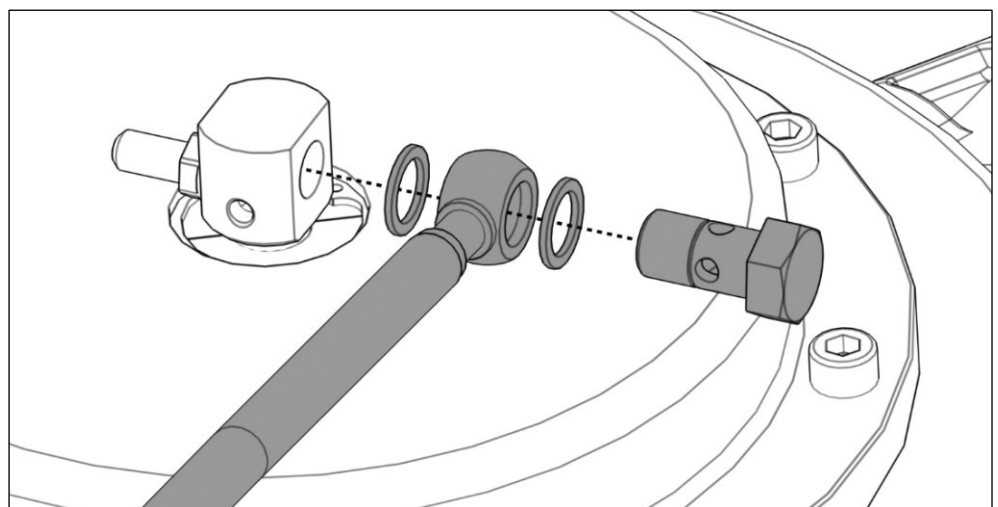

Fig. 14



### Maximum hose length between the fan and valve

Hub	Hose length
H162	→ DN4 max. 2.0 m
	→ DN5 max. 1.5 m
H222, H252	→ DN5 max. 4.0m
	→ DN6 max. 2.5m

### WARNING!

An incorrectly mounted high-pressure hose may cause collision!

The gap between blades in the transverse position and the high-pressure hose must be at least 5 mm wide!

- If necessary, loosen the banjo bolt.
- Correct the angle between the hose and the fan.
- Retighten the banjo bolt.

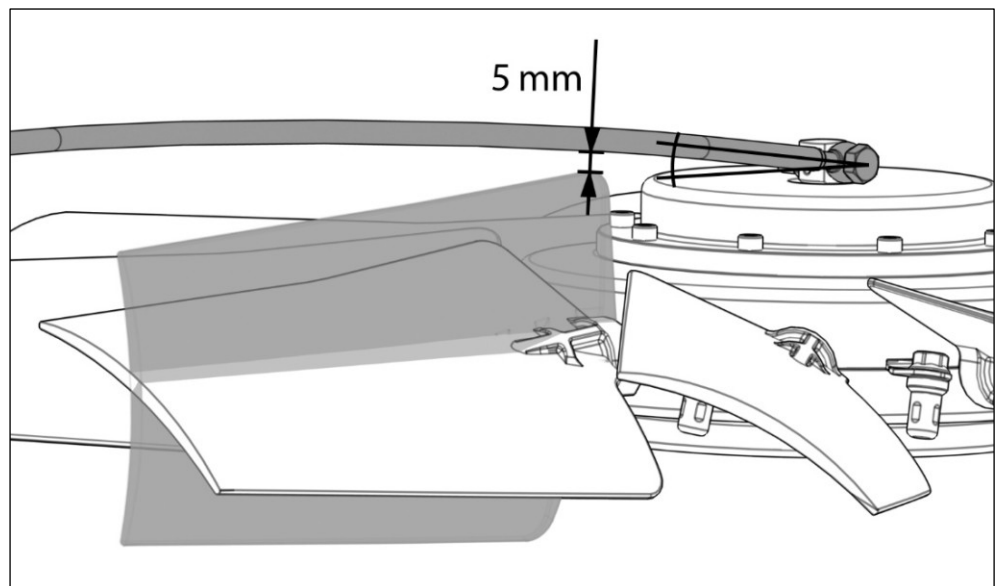

Fig. 15

- 2) Set the angle between the fan and the pressure hose.



### Angle between the fan and pressure hose

Hub-blade combination	Angle range
H162-Z15, H222-Z50, H252-Z50	→ 0° - 10°
H162-Z20, H222-Z60, H252-Z60	→ 10° - 20°
H252-X85	→ 15° - 25°

- 3) Tighten the banjo bolt to 20 Nm.

### 5.3 Mounting the Cleanfix® reversible fan

1) Drill a hole in the shroud as close as possible to the radiator.



Hole diameter in the shroud

Hose type

Hydraulic hose

Pneumatic hose

Hole diameter

→ 20 mm

→ 16 mm

2) Mount the hose screw connection included in the installation kit.



Position of the drilled hole for the pressure hose

Drilling the hole in the lower half of the shroud's side wall is preferable (Fig. 16).

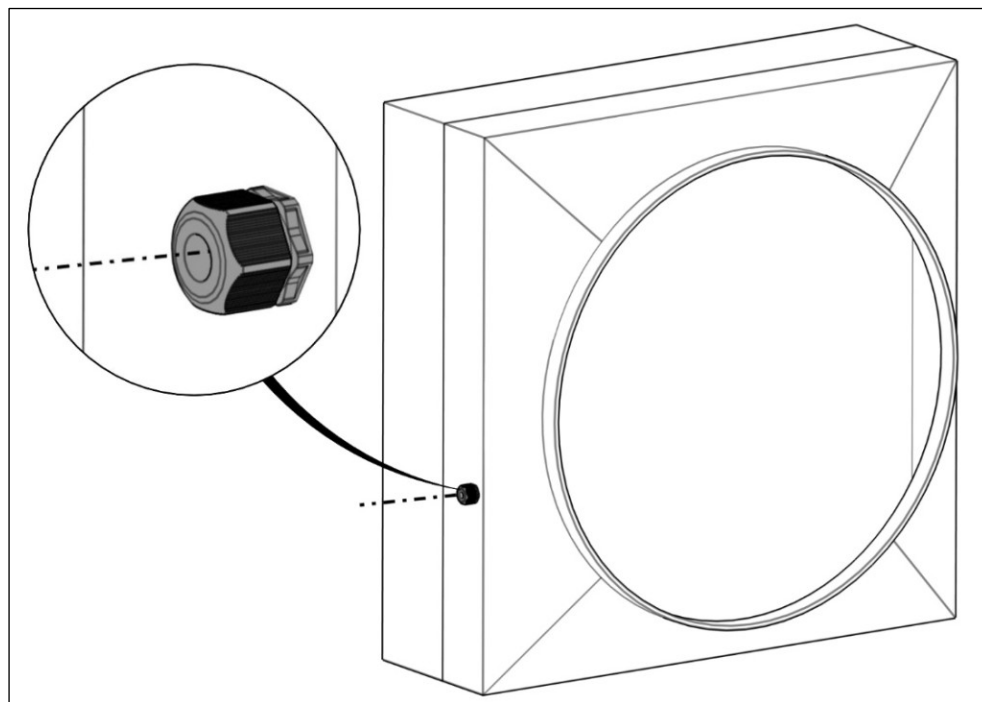

Fig. 16



**NOTE**

**Carelessly inserting the fan may cause property damage!**

If the fan is inserted carelessly into the shroud, the radiator fins can be damaged from impacts with the fan.

- If necessary, protect the radiator fins with cardboard.
- Make sure that the fan does not damage the radiator during insertion.

3) Carefully insert the Cleanfix® reversible fan into the shroud.

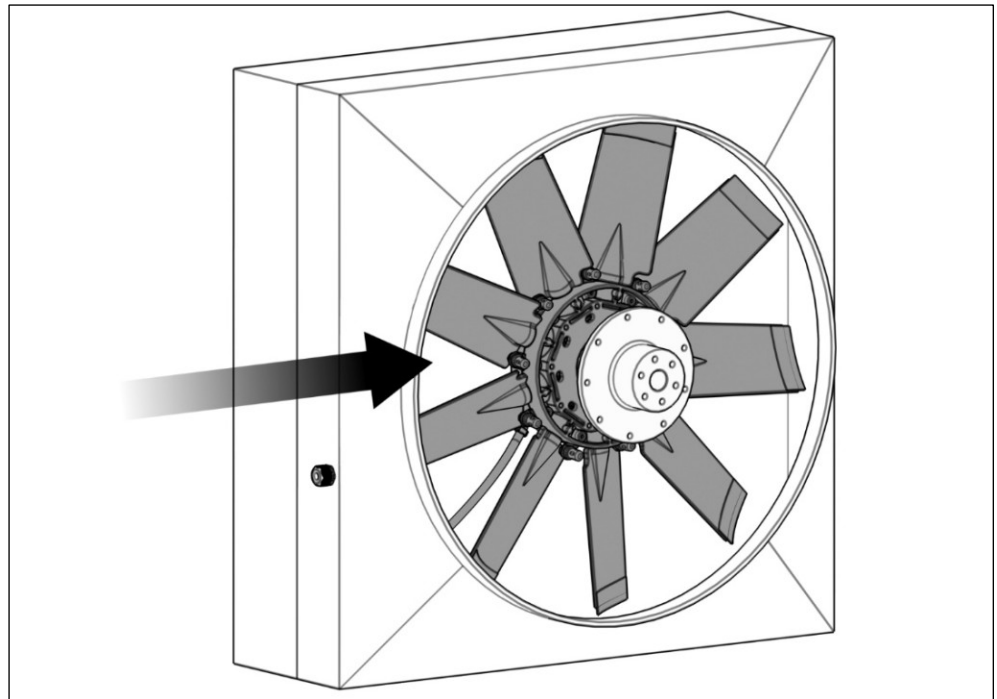

Fig. 17

4) Guide the pressure hose along the inside of the shroud through the hose screw connection.

- 5) Attach the fan to the flange using the provided locking screws.
- 6) Tighten the locking screws to the specified torque.



---

**Tightening torque for locking screws**

Fan model:

C162, H162

C222, H222, C252, H252

Torque

→ 12 Nm

→ 20 Nm

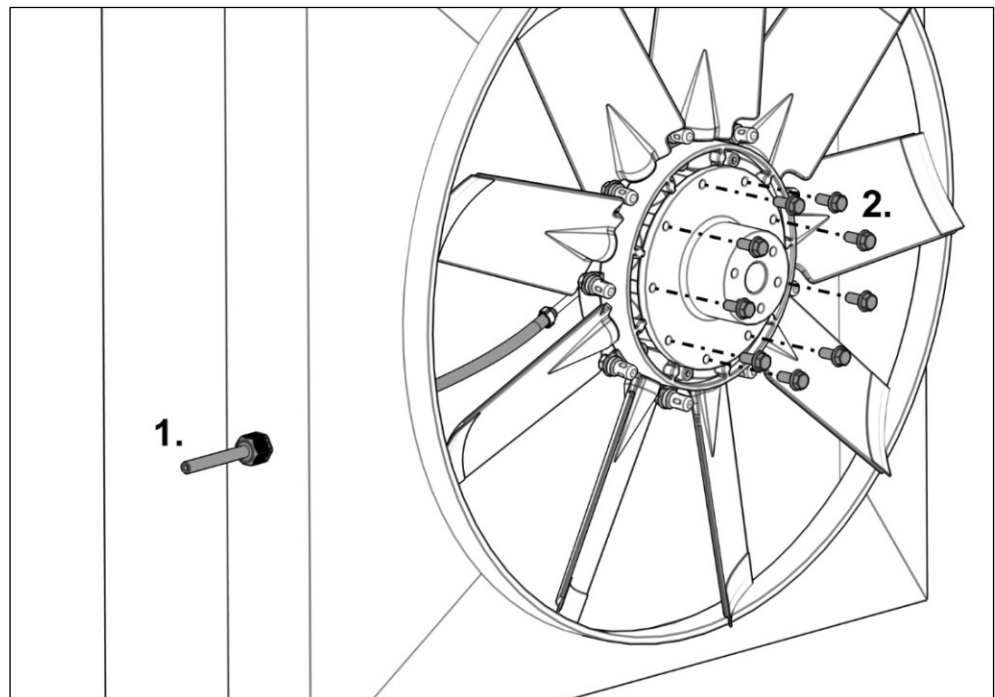

Fig. 18



**Maximum airflow rate**

So that the fan can reach its maximum airflow rate, the optimum installation depth must be observed when the fan is installed in the shroud.

- The fan must be able to move freely within the shroud, even with turned blades
- The best position cannot always be achieved due to space limitations.

During installation, verify that 1/3 of the blade profile is outside of the shroud for a suction fan and 2/3 of the blade profile is outside for a blowing fan.

**Blade profile for a suction fan**

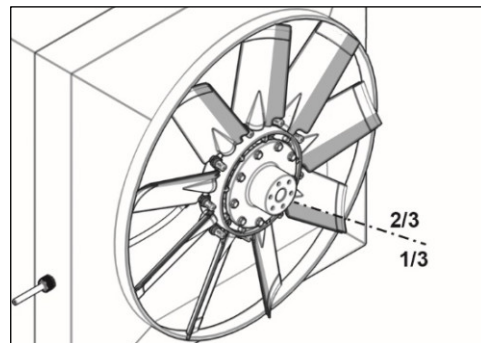

Fig. 19

**Blade profile for a blowing fan**

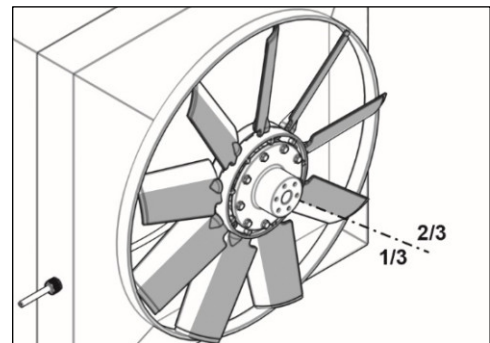

Fig. 20

- 7) Pull the pressure hose through the hose screw connection.  
→ Make sure that the hose cannot be caught by the blades.

**NOTE**

**Incorrect mounting of the pressure hose may cause property damage!**

When the pressure hose is mounted, it may be positioned too close to the blades. As a result, the blades may graze and damage the hose during operation.

- Manually position the pressure hose a distance away from the blades.

- 8) Secure the pressure hose with the compression nut of the hose screw connection.

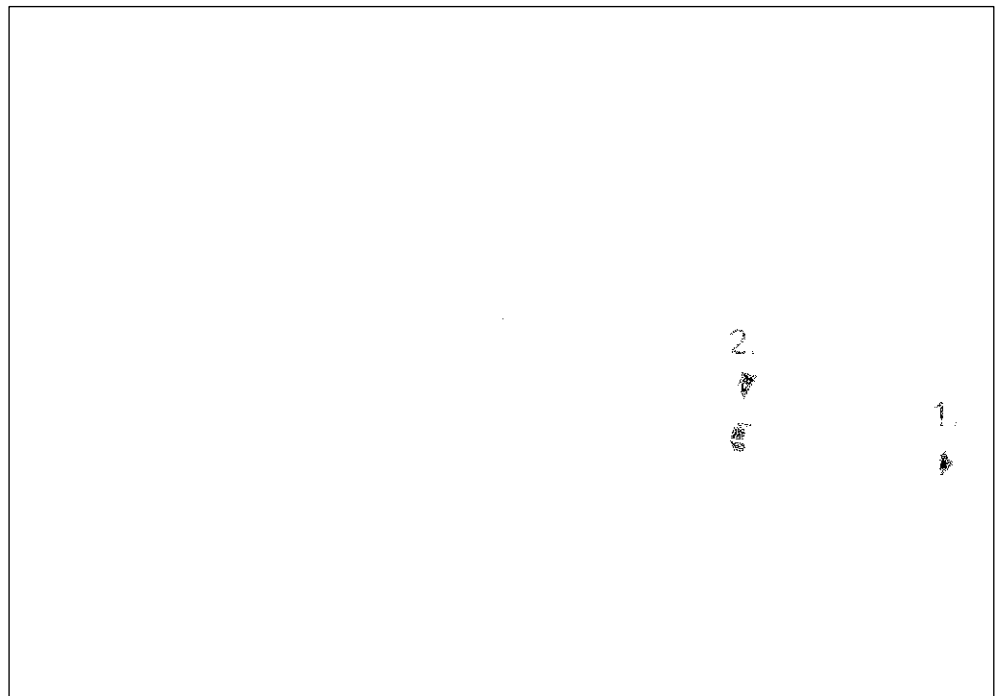

Fig. 21

**NOTE**

**Excessive tension on the pressure hose may cause property damage!**

If the air intake assembly on the fan is under tension from the hose, the seals on the air intake assembly will wear out and the fan will start leaking.

The pressure hose is ideally secured when it is possible to rotate the air intake assembly by maximum 15°.

- If necessary, open the hose screw connection again.
- Retension the hose appropriately.
- Close the hose screw connection again.

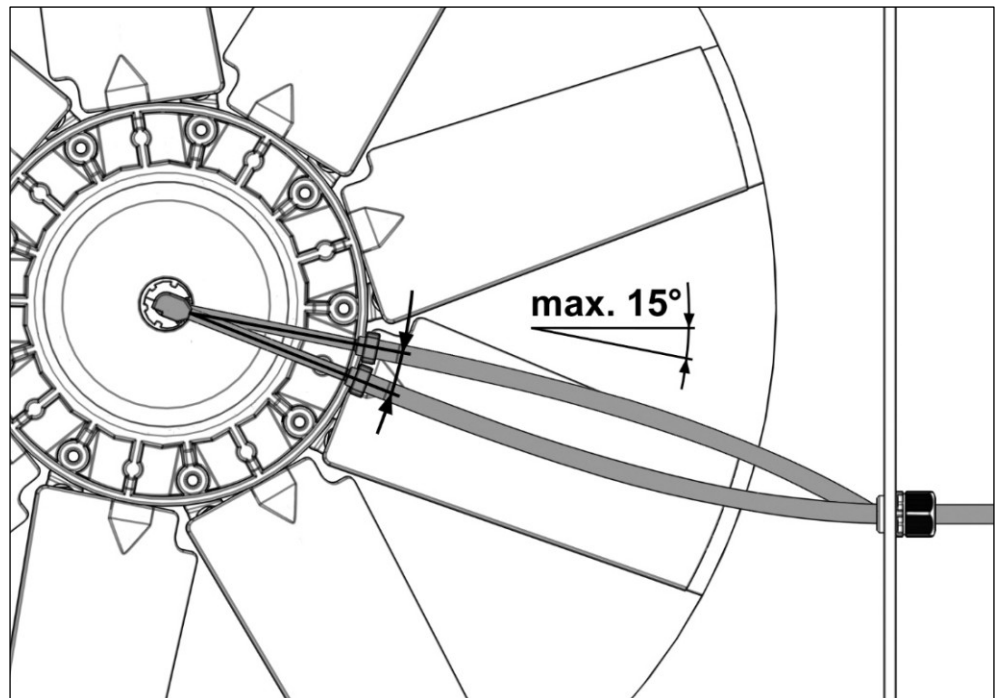

Fig. 22



For large fans (diameter of 900+ mm), support the hose halfway between the air intake assembly and the hose screw connection.

## 5.4 Checking the smooth movement of the Cleanfix® reversible fan

### 5.4.1 Pneumatic

- 1) Supply compressed air (max. 10 bar) to the fan.  
→ This causes the blades to turn to the transverse position.

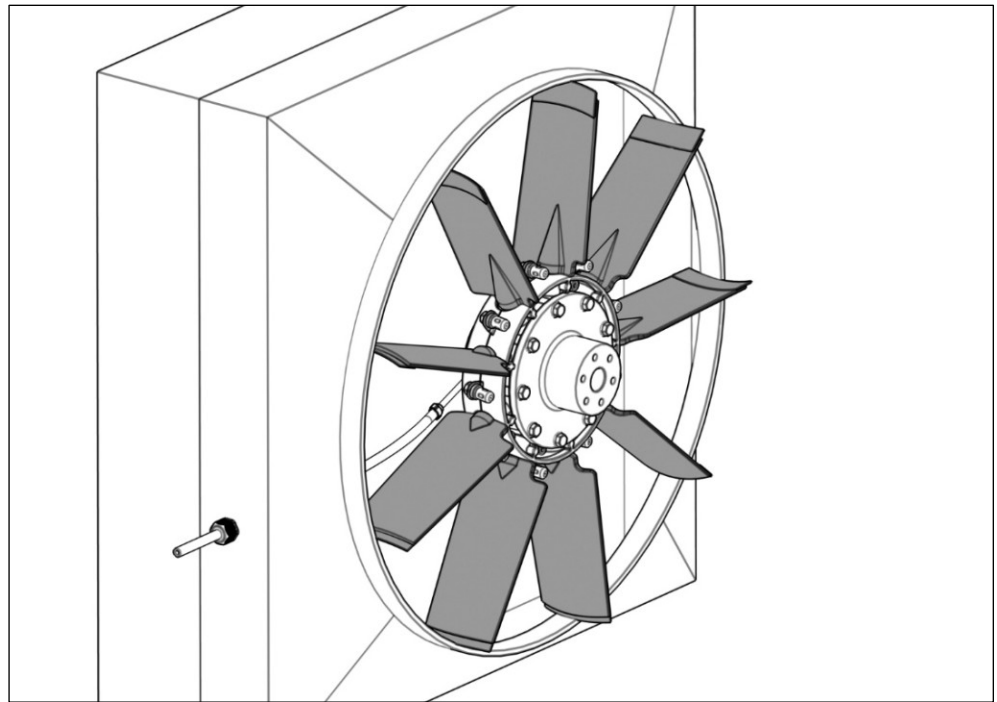

Fig. 23

- 2) Use locking pliers to pinch the pressure hose.  
→ This will trap the air in the system.
- 3) Remove the pressure hose from the compressed air supply.

**⚠ WARNING!**

**Pulling in of loose objects!**

Loose objects can be pulled into the fan during operation, which may result in property damage to the fan and vehicle and cause serious injury!

- Remove loose objects or secure them with plastic ties, where appropriate.

**NOTE**

**Rotating the fan with tight drive belts may cause property damage!**

Rotation of the fan with tight belts results in excessive force and may result in damage to the fan and drive.

- Loosen the drive belts.

- 4) Manually rotate the fan.

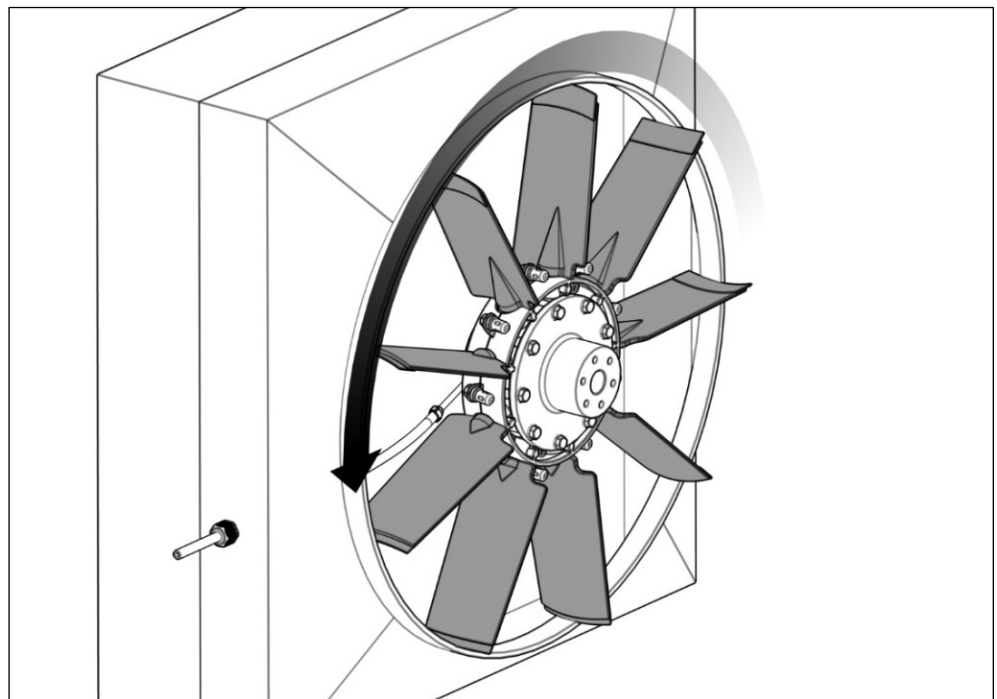

Fig. 24

- 5) Make adjustments as needed.
- 6) Remove the locking pliers.

### 5.4.2 Hydraulic

The blades cannot be moved to the transverse position when they are not in motion.

- 1) Measure whether interfering contours or obstructions are in the way.

For the measurement method, see the figure:

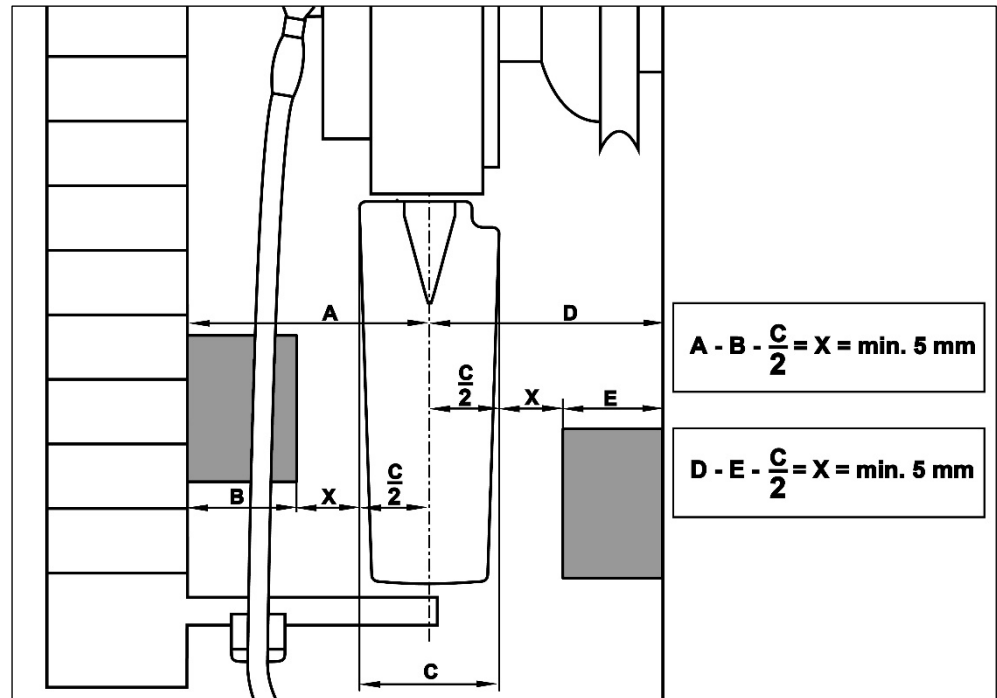

Fig. 25

A = distance from the radiator to the center of the blade

B = interfering contour on the radiator side

C = blade width

D = distance from the center of the blade to the engine

X = gap min. 5 mm

#### **⚠ WARNING!**

##### **Pulling in of loose objects!**

Loose objects can be pulled into the fan during operation, which may cause serious injury and result in damage to the fan and vehicle!

- Remove loose objects or secure them with plastic ties.



## 5.5 Mounting the hydraulic hose fitting (only for H162 fans)

- 1) Lubricate the outside of the hose end of the high-pressure hose.
- 2) Manually turn the screw sleeve counterclockwise (left-handed thread) onto the high-pressure hose.

### NOTE

**Misaligning the screw sleeve on the hose may cause property damage!**

Turning the screw sleeve when it is misaligned may cause damage and leaks at the hose.

- Screw the screw sleeve straight onto the hose.

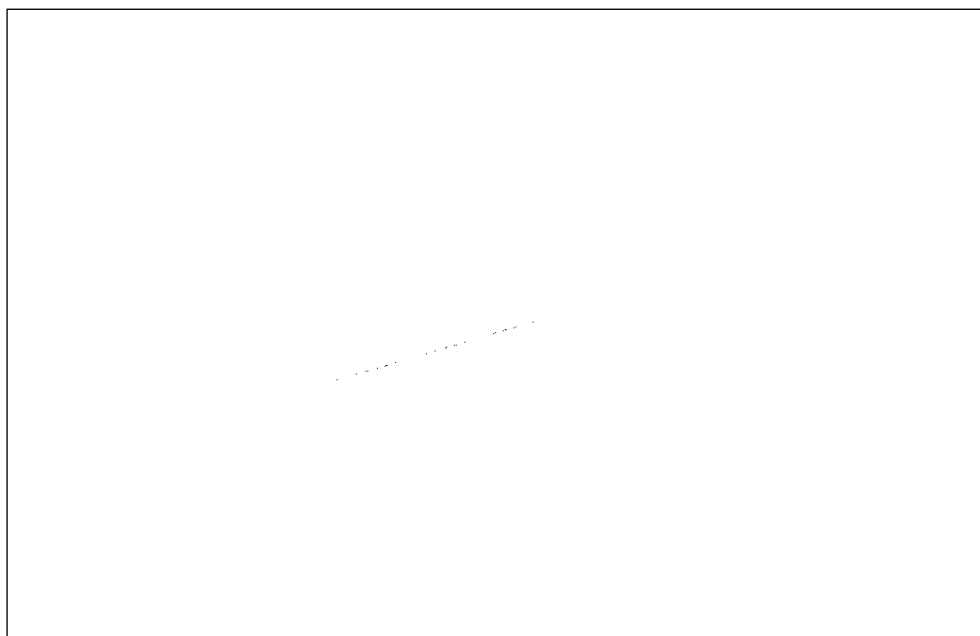

Fig. 26

- 3) Use a 12 mm wrench to screw the screw sleeve counterclockwise onto the high-pressure hose until it stops.

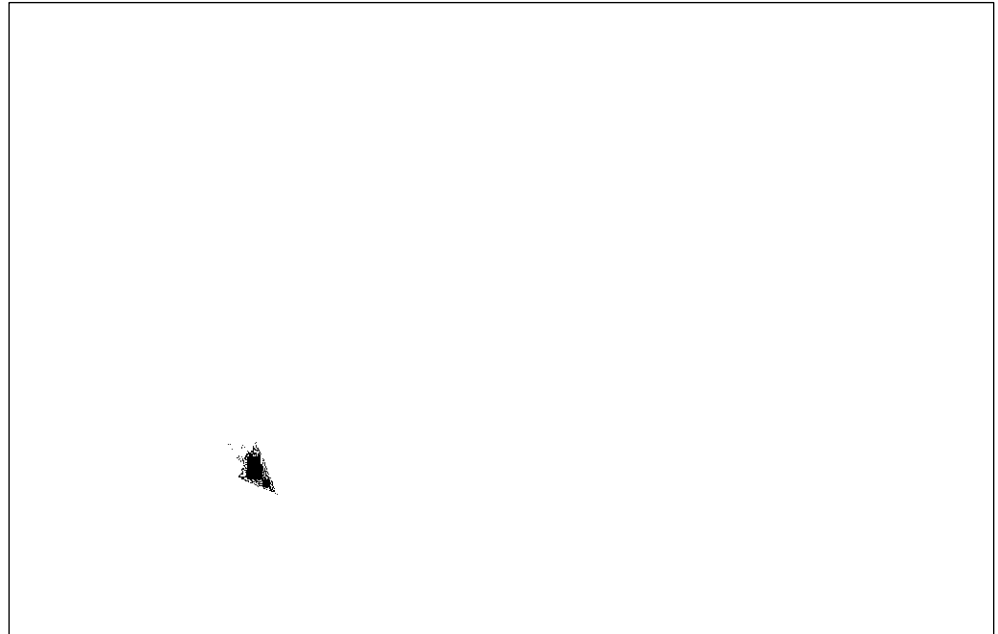

Fig. 27

- 4) Rotate a tube connector with right-hand thread into the screw sleeve.
- 5) Use a 12 mm wrench to hold the screw sleeve in place.
- 6) Use a 10 mm wrench to screw the tube connector onto the screw sleeve until it stops.

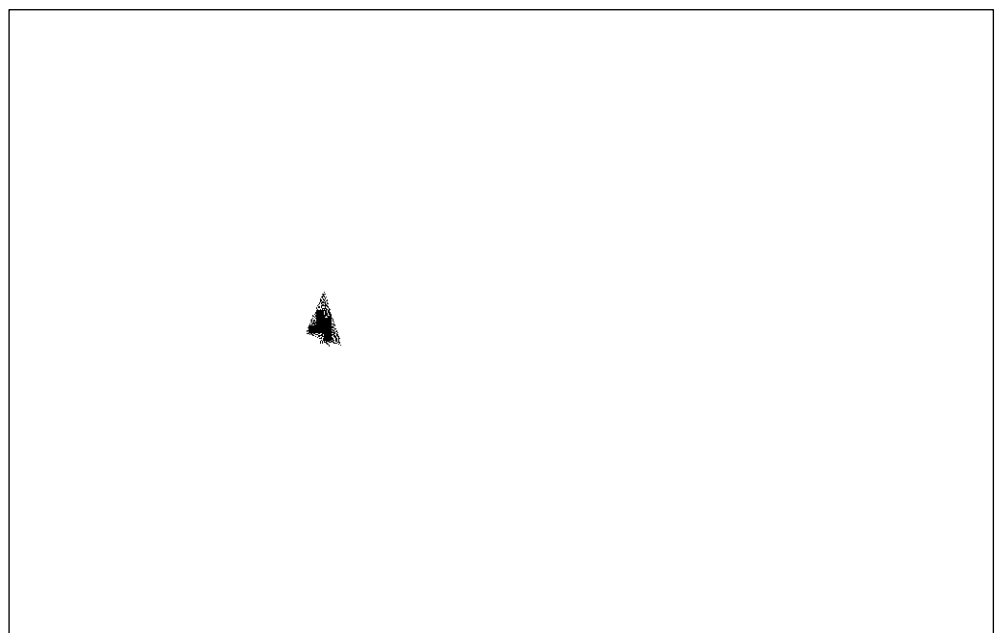

Fig. 28

## 6 Mounting the Cleanfix® electrical components

This chapter describes how to mount the Cleanfix® electrical components.

---

**NOTE**

---

**Property damage due to fire hazard!**

- The vertical gap between the fan and the control must be at least 200 mm and the horizontal gap at least 20 mm.
- See DIN 45545-2.

---

**An incorrect power supply may cause property damage!**

Cleanfix® electrical components are available for vehicles with 12 V and 24 V power supplies.

- Make sure that the compressor and valve are suitable for the existing voltage source.

---

**High temperatures may cause property damage!**

The temperature for Cleanfix® electrical components must not exceed 70 °C.

- Attach the unit at a heat-protected location.

---

**Splashing water and vibrations may cause property damage!**

Cleanfix® electrical components can be damaged by strong vibrations and splashing water.



- Attach the unit in a location protected from water and vibrations.
-

### Overview of the Cleanfix® electrical components

Cleanfix® offers a number of control solutions. The reversing function is activated pneumatically or hydraulically and controlled electronically.

The Cleanfix® electrical components are mounted as described in the following sections. The relevant section must be taken into account depending on the delivered version.

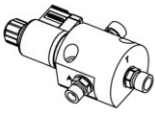
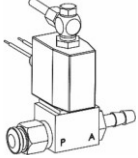
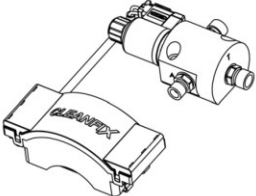
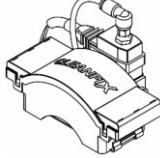
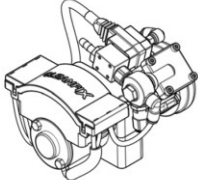
The corresponding versions are differentiated on the next page and references to the corresponding chapters are provided.

Reversing function	Hydraulic activation	Pneumatic activation	
	For vehicles with a hydraulic system	For vehicles with a compressed air system	For vehicles without a compressed air system
Press the push button to change from cooling to cleaning. The fan remains in cleaning mode for as long as the push button is pressed.	Valve  Fig. 29	Valve  Fig. 30	
Briefly press the push button to automatically change from cooling to cleaning and back again. Switching from cooling to cleaning and back is time-controlled, for example, every 30 minutes. This interval can be changed as desired. Intermediate cleaning can be performed at any time by pressing the push button.	Mini-Timer valve unit  Fig. 31	Mini-Timer valve unit  Fig. 32	Mini-Timer control unit-  Fig. 33 E-Box  Fig. 34

6.1 For pneumatic activation

6.1.1 Cleanfix® valve / for railway vehicles with a compressed air system

**NOTE**

Property damage due to fire hazard!

- The vertical gap between the fan and the control must be at least 200 mm and the horizontal gap at least 20 mm.
- See DIN 45545-2.

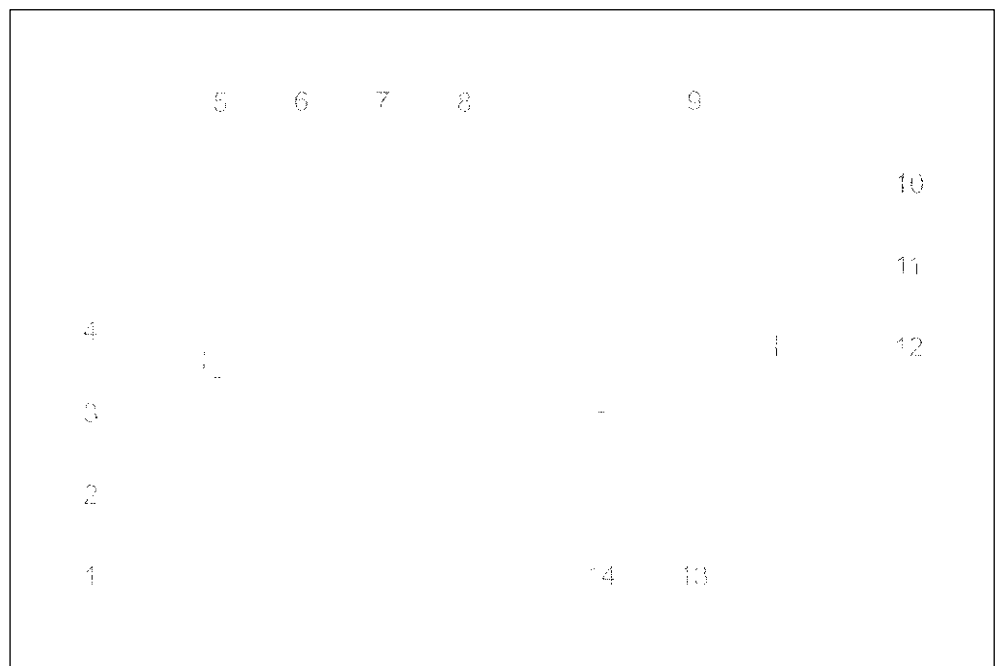

Fig. 35

- (1) Pressure hose (fuel line)
- (2) Hose screw connection
- (3) Hose clamp
- (4) Radiator
- (5) Shroud
- (6) Cleanfix® reversible fan (pneumatic)
- (7) Flange
- (8) Cleanfix® valve
- (9) Switch (push button)
- (10) Fuse (12 V / 24 V : 3 A)
- (11) Keyed power (terminal 15) [red cable]
- (12) Vehicle ground (terminal 31) [black cable]
- (13) Compressed air reservoir
- (14) Overflow valve

### Mounting the Cleanfix® valve

- 1) Determine the mounting location for the Cleanfix® valve.



---

#### Mounting location for the Cleanfix® valve

The Cleanfix® valve may be mounted in the vehicle cab, on the vehicle chassis, near the hydraulic system, or in the engine compartment.

The preferred mounting location is the cooler side of the engine (away from the exhaust manifold and muffler).

---

- 2) Use the supplied screws to mount the Cleanfix® valve.

### Connecting the Cleanfix® valve with the pressure hose of the Cleanfix® reversible fan

- 3) Cut the pressure hose to a suitable length.
- 4) Slide the hose clamp over the pressure hose.
- 5) Slide the pressure hose over the hose fitting of the Cleanfix® valve.
- 6) Secure the pressure hose by pinching the ears of the hose clamp with pincers.

### Connecting the Cleanfix® valve to the vehicle's compressed air system



---

#### Cleanfix® valve connection to the compressed air system

If an auxiliary consumer circuit (fused compressed air circuit) is available at the vehicle's compressed air system, this circuit can be used to save installation time.

If an auxiliary consumer circuit is not available at the vehicle's compressed air system, then a pressure relief valve must be connected between the Cleanfix® valve and the compressed air system.

---

- 7) Connect the Cleanfix® valve to the compressed air system.

### Mounting the push button

- 8) Determine the mounting location for the push button in the vehicle cab.



---

#### Push button mounting location

If an unassigned OEM push button is available in the vehicle cab, then this push button can be used to save installation time.

If no unassigned OEM push buttons are available on the vehicle, the supplied push button can be used.

---

- 9) Drill a 22 mm diameter hole for the push button.

#### **NOTE**

---

#### **Drilling into cables may cause property damage!**

Cables and electrical components run under the consoles and other components in the vehicle cab. These cables and components can be damaged during drilling.

- Make sure that no cables or electrical components will be drilled into at the location to be drilled.
  - Drill carefully and interrupt the drilling process several times to check whether cables or electrical components are in the way.
- 

- 10) Mount the push button.

### Connecting the Cleanfix® valve and push button to the vehicle's power supply

11) Determine the power supply to which the Cleanfix® valve and the push button can be connected.



---

#### Power connection for the Cleanfix® valve and push button

If a switched and fused circuit with a sufficient power supply (12 V / 24 V : 3 A) is available in the vehicle, then this circuit can be used to save installation time.

If a switched and fused circuit is not available in the vehicle, then the supplied push-on connection with fuse can be used.

---

12) Connect the Cleanfix® valve and push button to the vehicle's power supply.



### 6.1.2 Cleanfix® valve unit / for vehicles with a compressed air system

#### NOTE

Property damage due to fire hazard!

- The vertical gap between the fan and the control must be at least 200 mm and the horizontal gap at least 20 mm.
- See DIN 45545-2.



Fig. 36

- (1) Pressure hose (fuel line)
- (2) Hose screw connection
- (3) Hose clamp
- (4) Radiator
- (5) Shroud
- (6) Cleanfix® reversible fan (pneumatic)
- (7) Flange
- (8) Cleanfix® valve unit
- (9) Switch (push button)
- (10) Vehicle ground (terminal 31) [grey cable]
- (11) Fuse (12 V / 24 V: 3 A)
- (12) Keyed power (terminal 15) [red cable]
- (13) Vehicle ground (terminal 31) [black cable]
- (14) Compressed air reservoir
- (15) Overflow valve

### Mounting the Cleanfix® valve unit

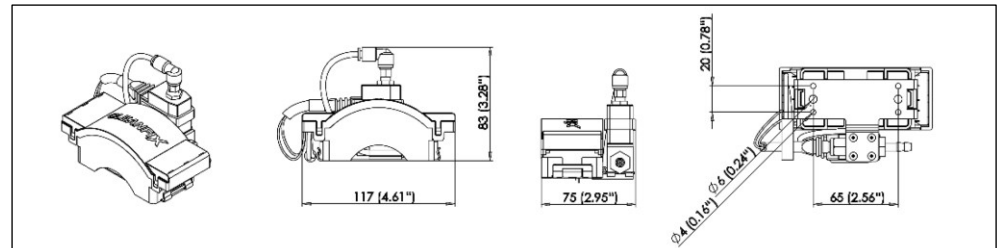

Fig. 37

- 1) Determine the mounting location for the Cleanfix® valve unit.



#### Mounting location for the Cleanfix® valve unit

The Cleanfix® valve unit may be mounted in the vehicle cab, on the vehicle chassis, near the hydraulic system, or in the engine compartment.

If the component is mounted in the engine compartment, the preferred location is on the cooler side of the engine (away from the exhaust manifold and muffler).

- 2) Use the supplied screws to mount the Cleanfix® valve unit.

#### Connecting the Cleanfix® valve unit with the pressure hose of the Cleanfix® reversible fan

- 3) Cut the pressure hose to a suitable length.
- 4) Slide the hose clamp over the pressure hose.
- 5) Slide the pressure hose over the hose fitting of the Cleanfix® valve unit.
- 6) Secure the pressure hose by pinching the ears of the hose clamp with pincers.

## Connecting the Cleanfix® valve unit to the vehicle's compressed air system



### Cleanfix® valve unit connection to the compressed air system

If an auxiliary consumer circuit (fused compressed air circuit) is available at the vehicle's compressed air system, this circuit can be used to save installation time.

If an auxiliary consumer circuit is not available at the vehicle's compressed air system, then a pressure relief valve must be connected between the Cleanfix® valve unit and the compressed air system.

7) Connect the Cleanfix® valve unit to the compressed air system.

### Mounting the push button

8) Determine the mounting location for the push button in the vehicle cab.



### Push button mounting location

If an unassigned OEM push button is available in the vehicle cab, then this push button can be used to save installation time.

If no unassigned OEM push buttons are available on the vehicle, the supplied push button can be used.

9) Drill a 22 mm diameter hole for the push button.

### NOTE

#### Drilling into cables may cause property damage!

Cables and electrical components run under the consoles and other components in the vehicle cab. These cables and components can be damaged during drilling.

- Make sure that no cables or electrical components will be drilled into at the location to be drilled.
- Drill carefully and interrupt the drilling process several times to check whether cables or electrical components are in the way.

10) Mount the push button.

## Connecting the Cleanfix® valve unit and push button to the vehicle's power supply

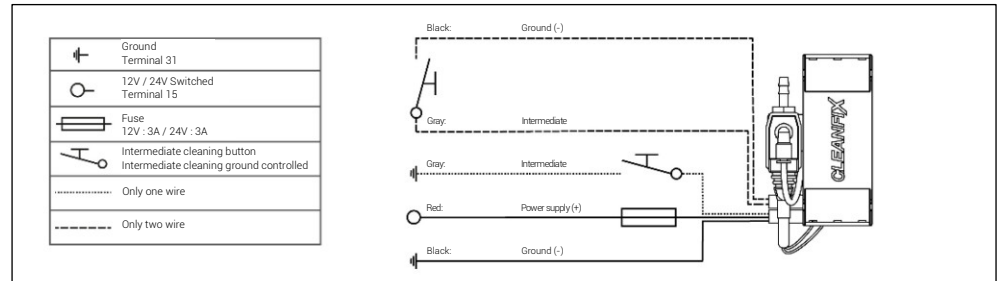

Fig. 38

11) Determine the power supply to which the Cleanfix® valve unit and the push button can be connected.



### Power connection for the Cleanfix® valve unit and push button

If a switched and fused circuit with a sufficient power supply (12 V / 24 V : 3 A) is available in the vehicle, then this circuit can be used to save installation time.

If a switched and fused circuit is not available in the vehicle, then the supplied push-on connection with fuse can be used.

12) Connect the Cleanfix® valve unit and push button to the vehicle's power supply.

### 6.1.3 Cleanfix® control unit

**NOTE**

Property damage due to fire hazard!

- The vertical gap between the fan and the control must be at least 200 mm and the horizontal gap at least 20 mm.
- See DIN 45545-2.



Fig. 39

- (1) Pressure hose (fuel line)
- (2) Hose screw connection
- (3) Hose clamp
- (4) Radiator
- (5) Shroud
- (6) Cleanfix® fan (pneumatic)
- (7) Flange
- (8) Cleanfix® control unit
- (9) Switch (push button)
- (10) Vehicle ground (terminal 31) [grey cable]
- (11) Fuse (12 V: 20 A / 24 V : 15 A)
- (12) Keyed power (terminal 15) [red cable]
- (13) Vehicle ground (terminal 31) [black cable]

### Mounting the Cleanfix® control unit

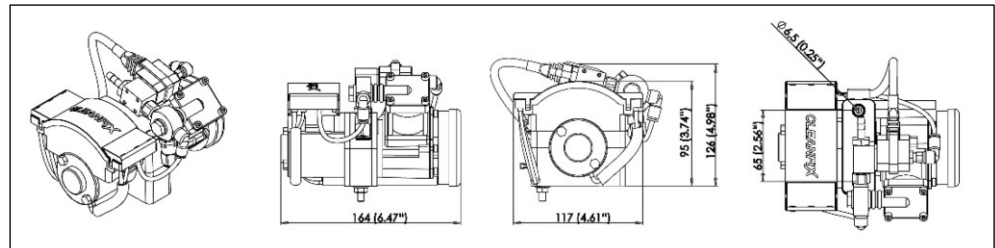

Fig. 40

- 1) Determine the mounting location for the Cleanfix® control unit.



#### Mounting location for the Cleanfix® control unit

The Cleanfix® control unit may be mounted in the vehicle cab, on the vehicle chassis, near the hydraulic system, or in the engine compartment.

When choosing the mounting location, keep in mind that the compressor of the Cleanfix® control unit generates a faint noise and vibrations when it operates.

When choosing the mounting location, make sure that the air filter of the Cleanfix® control unit is sufficiently protected from water.

- Rain
- Splashing water and spray mist from high-pressure cleaners
- Splashing water and spray mist from water on the wheel

If the component is mounted in the engine compartment, the preferred location is on the cooler side of the engine (away from the exhaust manifold and muffler).

- 2) Use the supplied screws to mount the Cleanfix® control unit.
- 3) Orient the air filter of the Cleanfix® control unit downward or to the side.

#### Connecting the Cleanfix® control unit with the pressure hose of the Cleanfix® reversible fan

- 4) Cut the pressure hose to a suitable length.
- 5) Slide the hose clamp over the pressure hose.
- 6) Slide the pressure hose over the hose fitting of the Cleanfix® control unit.
- 7) Secure the pressure hose by pinching the ears of the hose clamp with pincers.

### Mounting the push button

- 8) Determine the mounting location for the push button in the vehicle cab.



---

#### Push button mounting location

If an unassigned OEM push button is available in the vehicle cab, then this push button can be used to save installation time.

If no unassigned OEM push buttons are available on the vehicle, the supplied push button can be used.

---

- 9) Drill a 22 mm diameter hole for the push button.

#### **NOTE**

---

#### **Drilling into cables may cause property damage!**

Cables and electrical components run under the consoles and other components in the vehicle cab. These cables and components can be damaged during drilling.

- Make sure that no cables or electrical components will be drilled into at the location to be drilled.
  - Drill carefully and interrupt the drilling process several times to check whether cables or electrical components are in the way.
- 

- 10) Mount the push button.

## Connecting the Cleanfix® control unit and push button to the vehicle's power supply

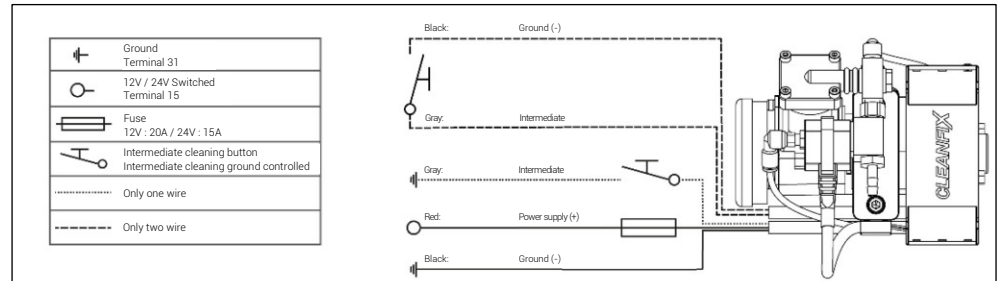

Fig. 41

11) Determine the power supply to which the Cleanfix® control unit and the push button can be connected.



### Power connection for the Cleanfix® control unit and push button

If a switched and fused circuit with a sufficient power supply (12 V : 20 A / 24 V : 15 A) is available in the vehicle, then this circuit can be used to save installation time.

If a switched and fused circuit is not available in the vehicle, then the supplied push-on connection with fuse can be used.

12) Connect the Cleanfix® control unit and push button to the vehicle's power supply.



## 6.1.4 Cleanfix® E-Box

### NOTE

Property damage due to fire hazard!

- The vertical gap between the fan and the control must be at least 200 mm and the horizontal gap at least 20 mm.
- See DIN 45545-2.

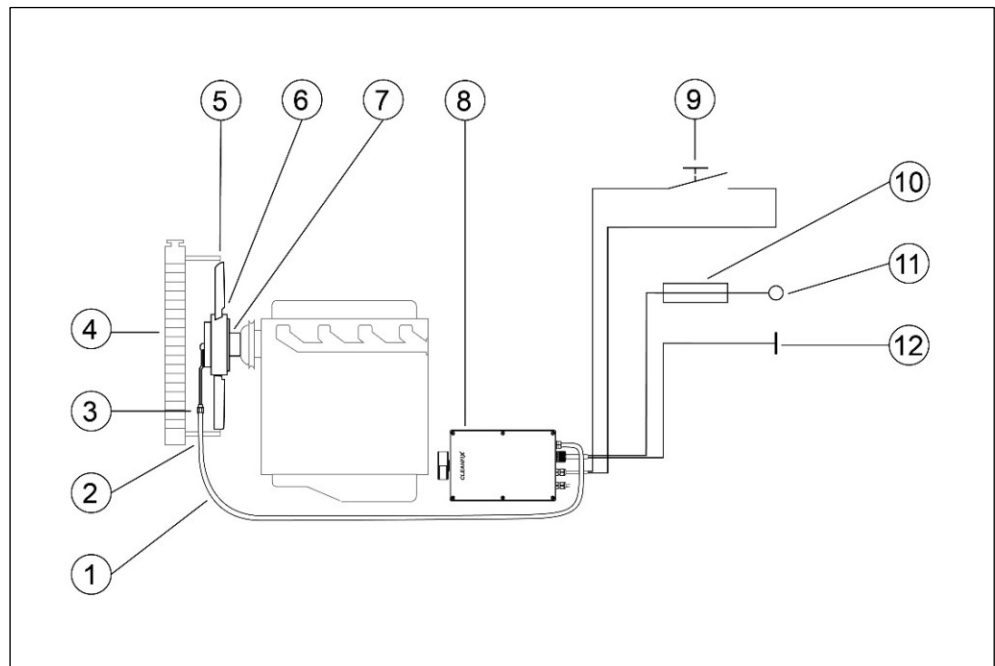

Fig. 42

- (1) Pressure hose (fuel line)
- (2) Hose screw connection
- (3) Hose clamp
- (4) Radiator
- (5) Shroud
- (6) Cleanfix® fan (pneumatic)
- (7) Flange
- (8) Cleanfix® E-Box
- (9) Switch (push button)
- (10) Fuse (12 V: 20 A / 24 V: 15 A)
- (11) Keyed power (terminal 15) [red cable]
- (12) Vehicle ground (terminal 31) [black cable]

## Mounting the Cleanfix® E-Box

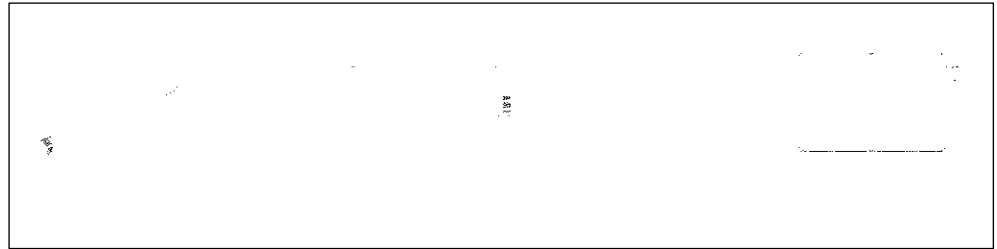

Fig. 43

13) Determine the mounting location for the Cleanfix® E-Box.



---

### Mounting location for the Cleanfix® E-Box

The Cleanfix® E-Box may be mounted in the vehicle cab, on the vehicle chassis, near the hydraulic system, or in the engine compartment.

When choosing the mounting location, keep in mind that the compressor of the Cleanfix® E-Box generates a faint noise and vibrations when it operates.

When choosing the mounting location, make sure that the air filter of the Cleanfix® E-Box is sufficiently protected from water.

- Rain
- Splashing water and spray mist from high-pressure cleaners
- Splashing water and spray mist from water on the wheel

If the component is mounted in the engine compartment, the preferred location is on the cooler side of the engine (away from the exhaust manifold and muffler).

---

14) Use the supplied screws to mount the Cleanfix® E-Box.

15) Orient the air filter of the Cleanfix® E-Box downward or to the side.

### Connecting the Cleanfix® E-Box with the pressure hose of the Cleanfix® reversible fan

16) Cut the pressure hose to a suitable length.

17) Slide the hose clamp over the pressure hose.

18) Slide the pressure hose over the hose fitting of the Cleanfix® E-Box.

19) Secure the pressure hose by pinching the ears of the hose clamp with pincers.

### Mounting the push button

20) Determine the mounting location for the push button in the vehicle cab.



---

#### Push button mounting location

If an unassigned OEM push button is available in the vehicle cab, then this push button can be used to save installation time.

If no unassigned OEM push buttons are available on the vehicle, the supplied push button can be used.

---

21) Drill a 22 mm diameter hole for the push button.

#### **NOTE**

---

#### **Drilling into cables may cause property damage!**

Cables and electrical components run under the consoles and other components in the vehicle cab. These cables and components can be damaged during drilling.

- Make sure that no cables or electrical components will be drilled into at the location to be drilled.
  - Drill carefully and interrupt the drilling process several times to check whether cables or electrical components are in the way.
- 

22) Mount the push button.

## Connecting the Cleanfix® E-Box and push button to the vehicle's power supply

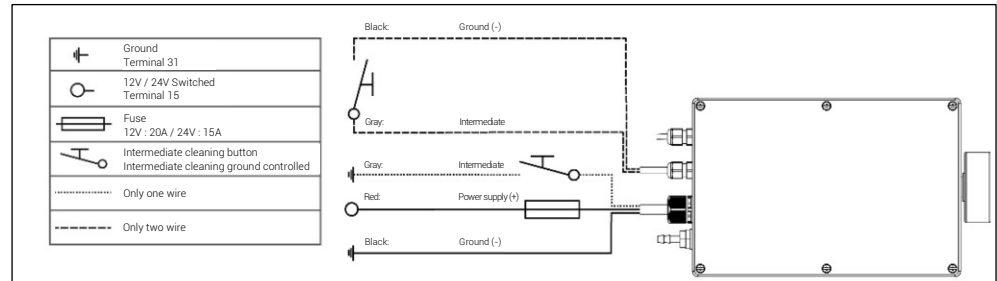

Fig. 44

23) Determine the power supply to which the Cleanfix® control unit and the push button can be connected.



### Power connection for the Cleanfix® control unit and push button

If a switched and fused circuit with a sufficient power supply (12 V : 20 A / 24 V : 15 A) is available in the vehicle, then this circuit can be used to save installation time.

If a switched and fused circuit is not available in the vehicle, then the supplied push-on connection with fuse can be used.

Connect the Cleanfix® control unit and push button to the vehicle's power supply.

## 6.2 For hydraulic activation

### 6.2.1 Cleanfix® valve / for vehicles with a hydraulic system

#### NOTE

Property damage due to fire hazard!

- The vertical gap between the fan and the control must be at least 200 mm and the horizontal gap at least 20 mm.
- See DIN 45545-2.

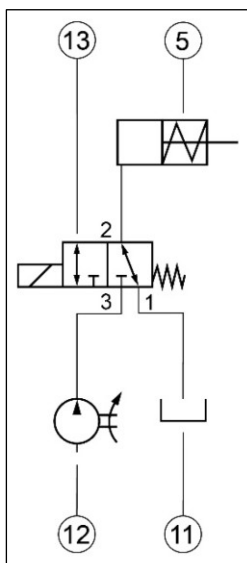

Fig. 45

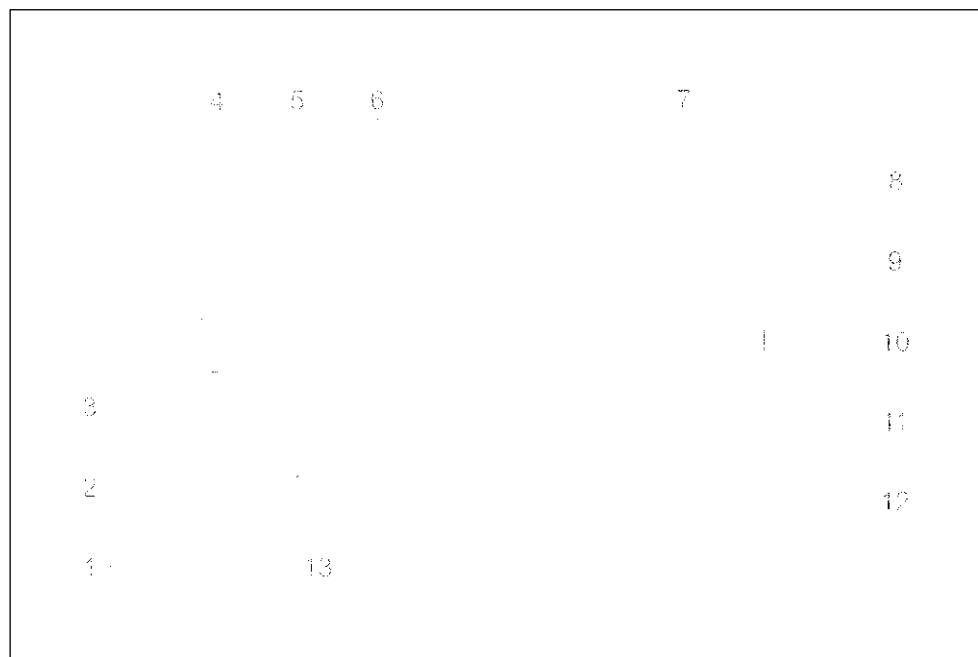

Fig. 46

- (1) Hose connection between the fan and valve
- (2) Hose screw connection
- (3) Radiator
- (4) Shroud
- (5) Cleanfix® reversible fan (hydraulic)
- (6) Flange
- (7) Switch (push button)
- (8) Fuse (12 V / 24 V : 3 A)
- (9) Keyed power (terminal 15)
- (10) Vehicle ground (terminal 31)
- (11) Hydraulic oil reservoir
- (12) Hydro pump
- (13) 3/2-way valve

### Mounting the Cleanfix® valve

- 1) Determine the mounting location for the Cleanfix® valve.



#### Mounting location for the Cleanfix® valve

The Cleanfix® valve may be mounted in the vehicle cab, on the vehicle chassis, near the hydraulic system, or in the engine compartment.

If the component is mounted in the engine compartment, the preferred location is on the cooler side of the engine (away from the exhaust manifold and muffler).

- 2) Use the supplied screws to mount the Cleanfix® valve.

### Connecting the Cleanfix® valve with the pressure hose of the Cleanfix® reversible fan

#### **NOTE**

#### Lengthening the pressure hose may cause property damage!

If the pressure hose is lengthened, the exchange of hydraulic oil within the Cleanfix® fan is no longer guaranteed.

- The supplied pressure hose must not be lengthened and must be connected directly to the Cleanfix® valve.



#### Maximum hose length between the Cleanfix® fan and Cleanfix® valve

Fan model:	Max. hose length
H162	→ DN4 max. 2.0 m
H222, H252	→ DN6 max. 3.5 m

- 3) Connect the pressure hose to the Cleanfix® valve.

## Connecting the Cleanfix® valve to the vehicle's hydraulic system



### Hydraulic pressure supply

Fan model:	Pressure supply
H162	→ min. 42 bar to max. 50 bar
H222, H252	→ min. 20 bar to max. 50 bar



### Return flow

The return flow must be implemented via a pipe connection at least 8 mm in diameter.

- 4) Use suitable pressure hoses to connect the Cleanfix® valve to the hydraulic system.

### Mounting the push button

- 5) Determine the mounting location for the push button in the vehicle cab.



### Push button mounting location

If an unassigned OEM push button is available in the vehicle cab, then this push button can be used to save installation time.

If no unassigned OEM push buttons are available on the vehicle, the supplied push button can be used.

- 6) Drill a 22 mm diameter hole for the push button.

### NOTE

#### Drilling into cables may cause property damage!

Cables and electrical components run under the consoles and other components in the vehicle cab. These cables and components can be damaged during drilling.

- Make sure that no cables or electrical components will be drilled into at the location to be drilled.
- Drill carefully and interrupt the drilling process several times to check whether cables or electrical components are in the way.

- 7) Mount the push button.

### Connecting the Cleanfix® valve and push button to the vehicle's power supply

- 8) Determine the power supply to which the Cleanfix® valve and the push button can be connected.



---

#### Power connection for the Cleanfix® valve and push button

If a switched and fused circuit with a sufficient power supply (12 V / 24 V : 3 A) is available in the vehicle, then this circuit can be used to save installation time.

If a switched and fused circuit is not available in the vehicle, then the supplied push-on connection with fuse can be used.

---

- 9) Connect the Cleanfix® valve and push button to the vehicle's power supply.



## 6.2.2 Cleanfix® valve unit with Mini-Timer or Multi-Timer / for vehicles with a hydraulic system

### NOTE

Property damage due to fire hazard!

- The vertical gap between the fan and the control must be at least 200 mm and the horizontal gap at least 20 mm.
- See DIN 45545-2.

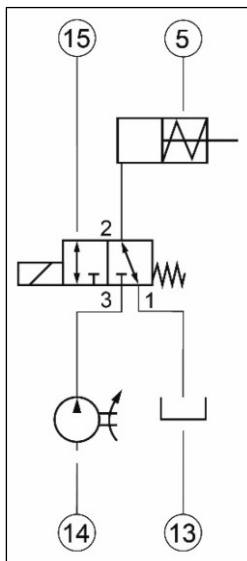

Fig. 47



Fig. 48

- (1) Hose connection between the fan and valve
- (2) Hose screw connection
- (3) Radiator
- (4) Shroud
- (5) Cleanfix® reversible fan (hydraulic)
- (6) Flange
- (7) Cleanfix® timer control with Mini-Timer or Multi-Timer
- (8) Switch (push button)
- (9) Vehicle ground (terminal 31) [grey cable]
- (10) Fuse (12 V / 24 V: 3 A)
- (11) Keyed power (terminal 15) [red cable]
- (12) Vehicle ground (terminal 31) [black cable]
- (13) Hydraulic oil reservoir
- (14) Hydro pump
- (15) 3/2-way valve

### Mounting the Cleanfix® valve unit

- 1) Determine the mounting location for the Cleanfix® valve unit.



#### Mounting location for the Cleanfix® valve unit

The Cleanfix® valve unit may be mounted in the vehicle cab, on the vehicle chassis, near the hydraulic system, or in the engine compartment.

If the component is mounted in the engine compartment, the preferred location is on the cooler side of the engine (away from the exhaust manifold and muffler).

- 2) Use the supplied screws to mount the Cleanfix® valve unit.

### Connecting the Cleanfix® valve unit with the pressure hose of the Cleanfix® reversible fan

#### **NOTE**

#### Lengthening the pressure hose may cause property damage!

If the pressure hose is lengthened, the exchange of hydraulic oil within the Cleanfix® fan is no longer guaranteed.

- The supplied pressure hose must not be lengthened and must be connected directly to the Cleanfix® valve unit.



#### Maximum hose length between the Cleanfix® fan and Cleanfix® valve unit

Fan model:	Max. hose length
H162	→ DN4 max. 2.0 m
H222, H252	→ DN6 max. 3.5 m

- 3) Connect the pressure hose to the Cleanfix® valve unit.

## Connecting the Cleanfix® valve unit to the vehicle's hydraulic system



### Hydraulic pressure supply

Fan model:	Pressure supply
H162	→ min. 42 bar to max. 50 bar
H222, H252	→ min. 20 bar to max. 50 bar



### Return flow

The return flow must be implemented via a pipe connection at least 8 mm in diameter.

- 4) Use suitable pressure hoses to connect the Cleanfix® valve unit to the hydraulic system.

### Mounting the push button

- 5) Determine the mounting location for the push button in the vehicle cab.



### Push button mounting location

If an unassigned OEM push button is available in the vehicle cab, then this push button can be used to save installation time.

If no unassigned OEM push buttons are available on the vehicle, the supplied push button can be used.

- 6) Drill a 22 mm diameter hole for the push button.

### NOTE

#### Drilling into cables may cause property damage!

Cables and electrical components run under the consoles and other components in the vehicle cab. These cables and components can be damaged during drilling.

- Make sure that no cables or electrical components will be drilled into at the location to be drilled.
- Drill carefully and interrupt the drilling process several times to check whether cables or electrical components are in the way.

- 7) Mount the push button.

Connecting the Cleanfix® valve unit and push button to the vehicle's power supply

- 8) Determine the power supply to which the Cleanfix® valve unit and the push button can be connected.



---

**Power connection for the Cleanfix® valve unit and push button**

If a switched and fused circuit with a sufficient power supply (12 V / 24 V : 3 A) is available in the vehicle, then this circuit can be used to save installation time.

If a switched and fused circuit is not available in the vehicle, then the supplied push-on connection with fuse can be used.

---

- 9) Connect the Cleanfix® valve unit and push button to the vehicle's power supply.

## 7 Setting the timer (push button)

**⚠ CAUTION!**

**Flying dirt may cause injuries!**

Persons near the radiator may be hit by flying dirt.

- Before activating the reversing function, make sure that nobody is in the vicinity of the radiator.
- Before activating the reversing function, make sure that the machine is not in a closed space.

**NOTE**

**Reversing the fan while the machine is in the red temperature range may result in damage!**

The cooling effect is interrupted when the reversing function is activated. Reversing the fan while the machine is in the red temperature range causes the engine to overheat.

- Do not reverse the fan when the machine is in the red temperature range.
- Park the machine and open the hood so that it can cool down.

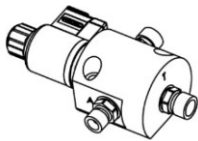
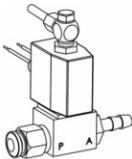

**Electronic component without timer (semi-automatic cleaning)**

Press the push button to change from cooling to cleaning. The fan remains in cleaning mode for as long as the switch is pressed. The cooling effect is interrupted when the reversing function is activated. Do not hold the push button down too long (see table).

Hydraulic activation	Pneumatic activation
With a hydraulic system in the machine Hold the push button down for max. 15 sec.	With a compressed air system in the machine Hold the push button down for max. 15 sec.
Valve  Fig. 49	Valve  Fig. 50

**Electronic component with timer (fully automatic cleaning at intervals)**

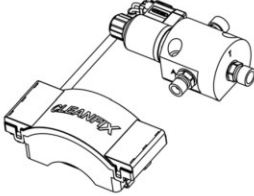
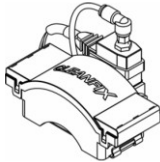
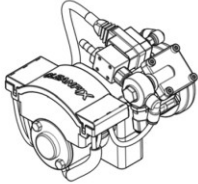
Switching from cooling to cleaning and back is controlled by the set interval, for example, every 30 minutes. This time interval can be modified as desired via the Cleanfix control app (see chapter 8). Intermediate cleaning can be performed manually at any time by pressing the push button or via the Cleanfix control app. By default, the first cleaning operation will start immediately after the power supply is attached. The first cleaning operation can be started after a time delay in customized solutions.

Hydraulic activation	Pneumatic activation	
With a hydraulic system in the machine	With a compressed air system in the machine	Without a compressed air system in the machine
Valve unit  Fig. 51	Valve unit  Fig. 52	Control unit  Fig. 53 E-Box  Fig. 54

## 8 Optional: Operation (Cleanfix control app)

### CAUTION!

**Activation of the reversing function while persons are standing in front of the vehicle may result in accidents!**

The fan generates strong air currents when it is in the cleaning position. Persons standing in front of the vehicle may be struck by flying dirt when the reversing function is activated.

- Nobody may be standing in front of the vehicle when the reversing function is activated.

**Activation of the reversing function in train stations may result in accidents!**

The fan generates strong air currents when it is in the cleaning position. In closed spaces, this may generate dust and result in damage or accidents due to flying parts.

- Use the reversing function only in a safe location and only outside of closed spaces.

### NOTE

**Reversing the fan while the machine is in the red temperature range may result in damage!**

The cooling effect is interrupted when the reversing function is activated. Reversing the fan while the machine is in the red temperature range causes the engine to overheat.

- Do not reverse the fan when the machine is in the red temperature range.
- Park the machine and open the hood so that it can cool down.



The installation of the Cleanfix control app is not mandatory for the operation of the electrical components with timer. Electrical components with timer can also be operated when the app is deactivated.

Cleanfix offers an app that can be used to operate the electronic components with timer and to make settings.

The Cleanfix control app provides the following functions:

- Switching between automatic and manual operation
- Setting the cycle time
- Pausing cleaning
- Pairing with the device
- Monitoring the air filter status
- Performing manual cleaning
- Performing a system check

## 8.1 Downloading the app

- 10) Open the app store on your mobile device.
- 11) Search for Cleanfix control app in the app store.
- 12) Download the Cleanfix control app.
- 13) Open the Cleanfix control app.



### Mobile device access

So that the app can access certain functions on your mobile device, you must accept the permissions.

The app requires Bluetooth access. Access might not be available in every country.

- 14) Follow the instructions on your mobile device.
- 15) If necessary, install the update.



### Updates

To ensure that the app will function optimally and is the current version, install all updates.

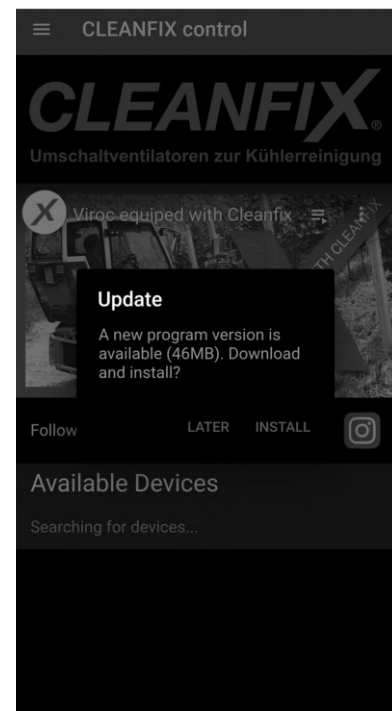

Fig. 55



8.2 Pairing the device

- 16) Tap the ☰ button to open the menu.
- 17) Select [Devices].

**i** For subsequent steps, the device must be turned on.

- If necessary, turn on the ignition.

- 18) Swipe downward to start the search for devices.
- 19) Select the relevant device.

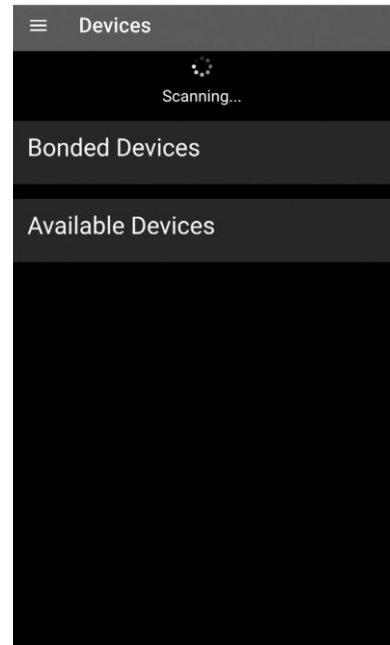
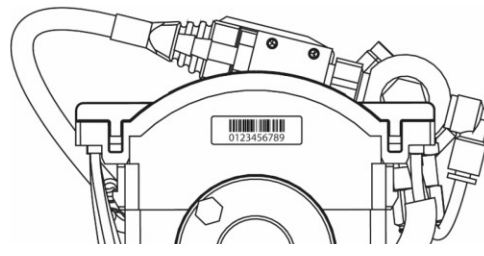

Fig. 56

- 20) Enter the PIN.

**i** The PIN consists of the last six digits of the device serial number.



- 21) Tap [Pairing] to confirm.

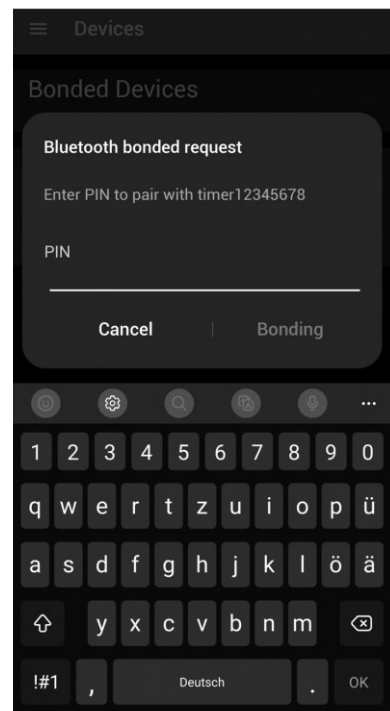

Fig. 57

- 22) Define the [device name].
- 23) Enter the average [altitude] of the working environment.
- 24) Tap [next] to confirm.

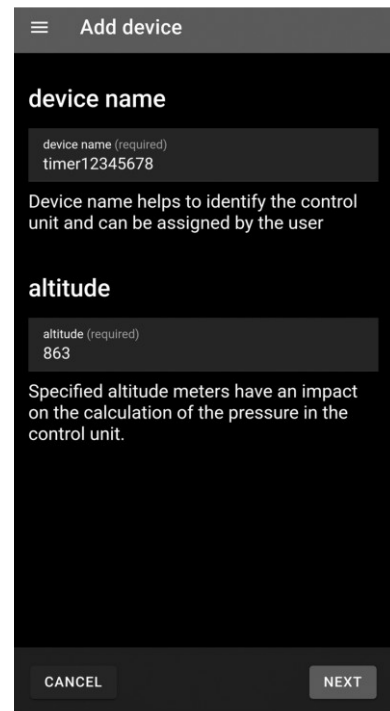

Fig. 58

- 25) Enter or scan the [serial number fan].
- 26) Tap [next] to confirm.

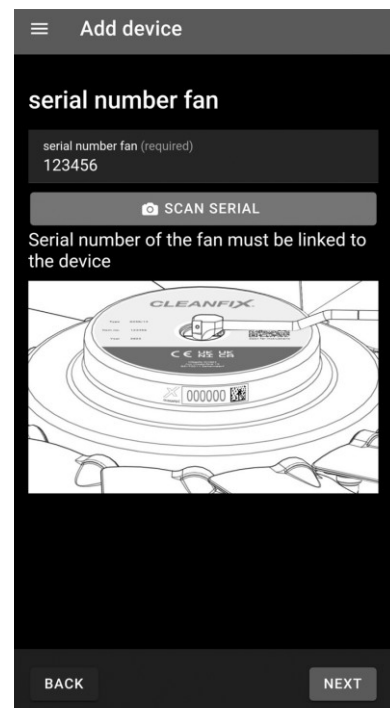



Fig. 59

8.3 Editing the device

- 27) Select the device from the [Devices] or the main screen.
- 28) Tap the  button to open the [Edit Device] dialog.
- 29) Adapt the information accordingly.
- 30) Tap [save] to confirm.

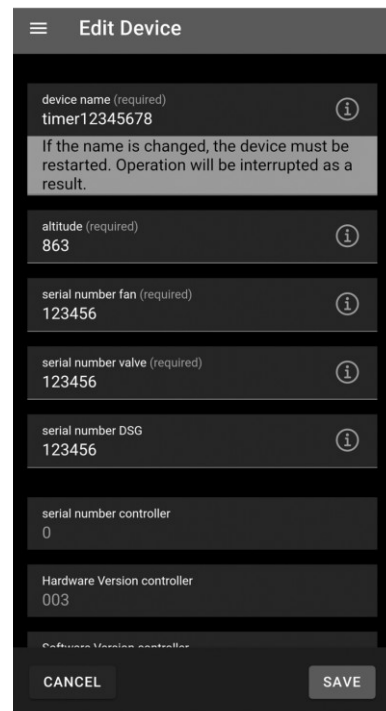



Fig. 60

8.4 Performing a system check

- 31) Select the device from the [Devices] or the main screen.
- 32) Tap the  button to open the [Check] dialog.
- 33) Tap the  button to start the system check.

**i** The system check is performed. The result is shown when the check is complete.

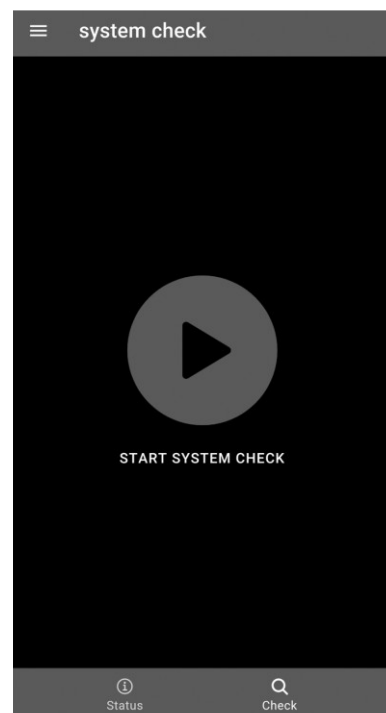

Fig. 61

### A) System check successful



#### Sharing the results

The result of the system check can be transmitted or saved as a PDF file via the [↔ share results] button.

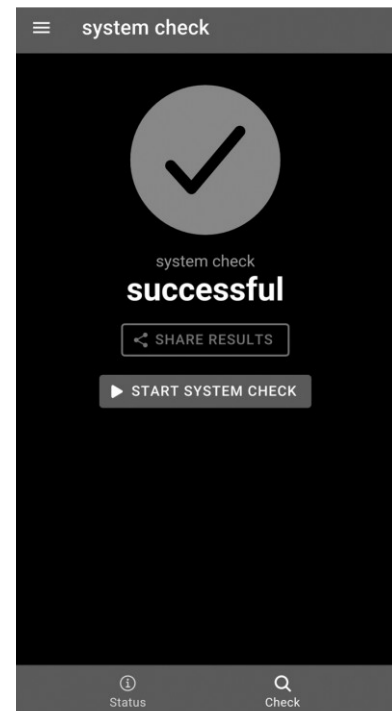

Fig. 62

### B) System check failed

- Contact the dealer or manufacturer.



#### Sharing the results

The result of the system check can be transmitted or saved as a PDF file via the [↔ share results] button.

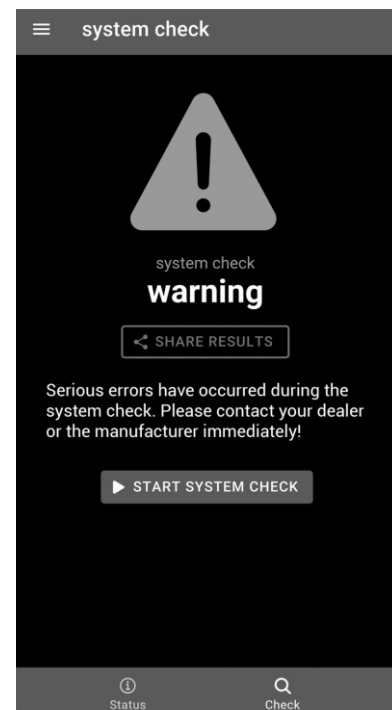

Fig. 63

## 8.5 Performing manual cleaning

- 34) Select the device from the [Devices] or the main screen.
- 35) Tap the [**\*** manual cleaning] button to performing manual cleaning.

**i** If [**\*** manual cleaning] is tapped during automatic operation, intermediate cleaning is performed. The cycle time then starts over.

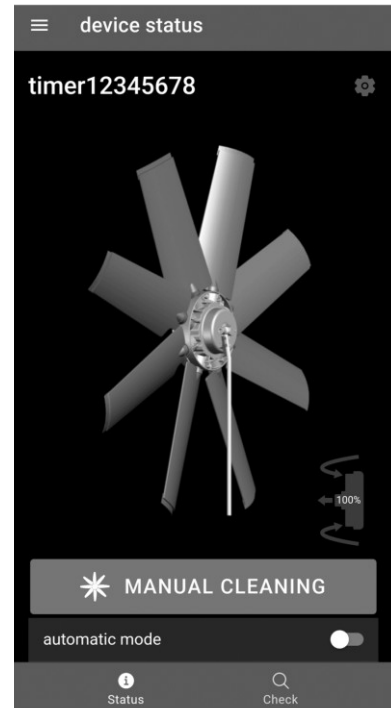

Fig. 64

## 8.6 Turning automatic operation on/off

- 36) Select the device from the [Devices] or the main screen.
- 37) In the [automatic mode] dialog, tap the switch to turn automatic operation on or off.
- 38) Select the [cycle time] dialog to set the cycle time.
- 39) Select a cycle time between 5 and 120 minutes.

**i** You can pause automatic operation by tapping the [|| pause] button and then resume automatic operation by tapping the [▶ resume] button.

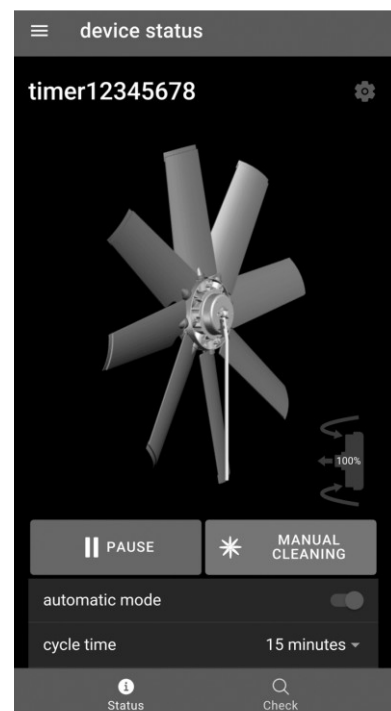

Fig. 65

## 8.7 Removing a device

- 40) Tap the ☰ button to open the menu.
- 41) Select the [Devices] menu screen.
- 42) Swipe the corresponding device to the left to display options.
- 43) Tap the 🗑️ button to remove the device.

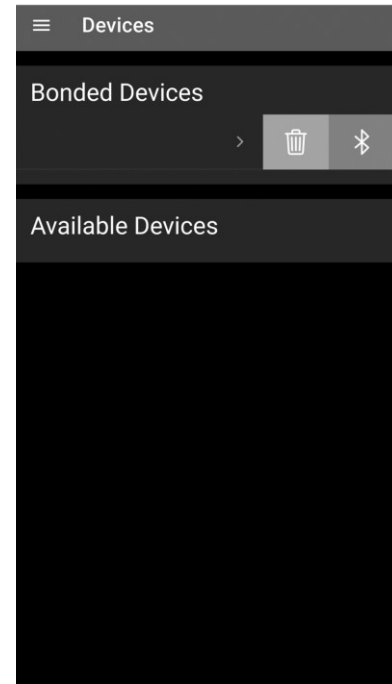

Fig. 66

## 8.8 Showing the air filter status

- i** The air filter on the device becomes clogged in the course of operation. This occurs depending on the operating time and the number of times the fan is reversed. The indicator on the filter symbol shows the air filter status. If the value falls below 10%, a corresponding message appears and filter replacement is recommended (see section 9.2).

- 44) Select the device from the [Devices] or the main screen.
- 45) Tap the 🌀 button to show the air filter status.
- 46) Tap [OK] to confirm.

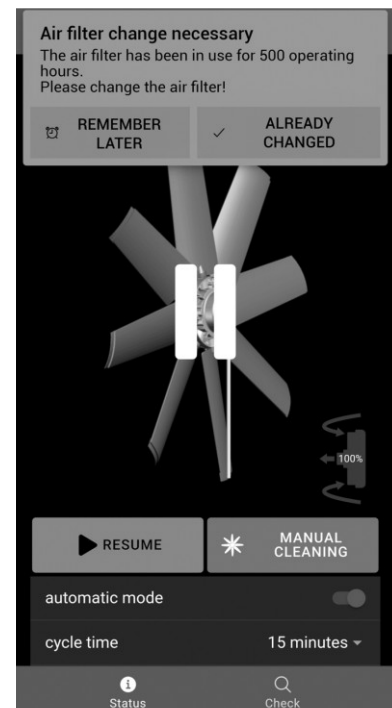

Fig. 67

## 9 Maintenance

### 9.1 Servicing the Cleanfix® reversible fan

Cleanfix® reversible fans are maintenance-free.

### 9.2 Servicing the Cleanfix® electrical components

For pneumatic electronic components with a compressor, the filter must be replaced at every maintenance interval of the machine, but at the least after 500 operating hours.

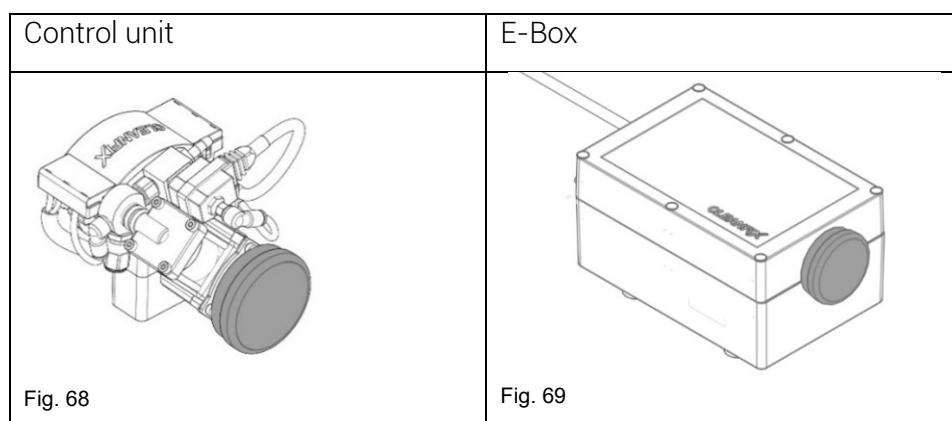

#### Air filter spare parts kit

Order number: 213259

## 10 Troubleshooting (fans)

### 10.1 Troubleshooting Cleanfix® pneumatic reversible fans

Error	Cause of error	Troubleshooting
1 Blades do not rotate to the cleaning position	<p>→ 1.1 No or low pressure supply (with a compressed air system)</p>	<p>→ 1.1.1 Check the compressed air supply at the solenoid valve.</p> <p>Compressed air supplied at the solenoid valve → see 1.1.2</p> <p>→ If no pressure is being applied to the solenoid valve, check the compressed air supply (min. 6.5 bar or 94 psi / max. 8 bar or 116 psi).</p> <hr/> <p>↳ 1.1.2 Check the functioning of the solenoid valve.</p> <p>If necessary, connect external power supply. (Please note: voltage 12 V or 24 V only)</p> <p>Solenoid valve switches (soft clicking) → see 1.1.3</p> <p>→ If the solenoid valve does not switch, replace the valve.</p> <hr/> <p>↳ 1.1.3 Check the pressure hose.</p> <p>If necessary, pull the pressure hose from the valve and connect it to the vehicle shop compressed air supply (max. 8 bar / 116 psi) to locate possible leaks faster.</p> <p>The pressure hose from the solenoid valve to fan has no kinks or leaks → see 1.1.4</p> <p>→ In the case of leaks in the hose, the hose needs to be replaced.</p> <p>→ When the air intake assembly on the fan is leaking, an appropriate seal kit must be ordered.</p>



---

↳ **1.1.4 Mechanical failure.**

If all the above conditions are met and the blades do not rotate, then the trouble is a mechanical error. The fan must be sent to the manufacturer for testing.

---

↳ **1.2 No or low pressure supply**  
(with electrical compressor)  
  
For a detailed error cause, the electrical component must be connected to the Cleanfix control App. A system check can be performed via the Cleanfix control app.  
  
Bluetooth must be active for the connection with the Cleanfix control app.

→ **1.2.1 Check the functioning of the compressor.**

If the compressor builds up pressure, the voltage may fall to max. 0.5 V below the rated voltage. Otherwise, the power supply must be checked and, if necessary, must be designed to be more stable (a different cross section, shorter cables, etc.).

Nominal voltage tolerance is maintained  
→ see 1.2.2

→ If it does not function, check the power supply.

---

↳ **1.2.2 Check the pressure build-up of the compressor.**

Check the pressure build-up of the compressor with suitable pressure gauge (max. 15 s / min. 6.5 bar or 94 psi) with the fan connected.

Compressor builds up enough pressure  
→ see 1.2.3

→ If the compressor does not build up enough pressure, replace the compressor.

---

↳ **1.2.3 Check the functioning of the solenoid valve.**

If necessary, connect external power supply. (Please note: voltage 12 V or 24 V only)

Solenoid valve switches (soft clicking)  
→ see 1.2.4

→ If the solenoid valve does not switch, replace the valve.

---

---

↳ **1.2.4** Check the pressure hose

If necessary, pull the pressure hose from the valve and connect it to the workshop compressed air supply (max. 8 bar / 116 psi) to locate possible leaks faster.

The pressure hose from the solenoid valve to fan has no kinks or leaks → see 1.2.5

- In the case of leaks in the hose, the hose needs to be replaced.
- When the air intake assembly on the fan is leaking, an appropriate seal kit must be ordered.

---

↳ **1.2.5** Mechanical failure.

If all the above conditions are met and the blades do not rotate, then the trouble is a mechanical error. The fan must be sent to the manufacturer for testing.

---

Error	Cause of error	Troubleshooting
<p>2 Blades do not return from the cleaning position to the cooling mode</p>	<p>→ 2.1 Fan speed is too high</p>	<p>→ 2.1.1 Reduce the speed.</p>
		<p>↳ 2.1.2 Install more springs, if possible</p> <p>Additional springs increase the release force. The fan must be sent to the manufacturer.</p>
	<p>↳ 2.2 Fan cannot vent anymore</p>	<p>→ 2.2.1 Check the pressure hose</p> <p>The pressure hose from the solenoid valve to fan has no kinks or pinched positions → see 2.2.2</p>
		<p>↳ 2.2.2 Check the functioning of the solenoid valve.</p> <p>If necessary, connect external power supply. (Please note: voltage 12 V or 24 V only)</p>
		<p>Solenoid valve switches (soft clicking) → see 2.2.3</p>
		<p>→ If the solenoid valve does not switch, replace the valve.</p>
		<p>↳ 2.2.3 Mechanical failure.</p> <p>If the fan with hose disconnected does not turn back in the idle state, there is a mechanical failure. The fan must be sent to the manufacturer for testing.</p>

## 10.2 Troubleshooting Cleanfix® hydraulic reversible fans

Error	Cause of error	Troubleshooting
1 Blades do not rotate to the cleaning position	→ 1.1 No or low pressure supply	<p>→ 1.1.1 Check the compressed air supply at the solenoid valve.</p> <p>Compressed air supplied at the solenoid valve → see 1.1.2</p> <p>→ If no pressure is being applied to the solenoid valve, check the compressed air supply (min. 20 bar or 94 psi / max. 50 bar or 116 psi).</p> <hr/> <p>↳ 1.1.2 Check the functioning of the solenoid valve.</p> <p>If necessary, connect external power supply. (Please note: voltage 12 V or 24 V only)</p> <p>Solenoid valve switches (soft clicking) → see 1.1.3</p> <p>→ If the solenoid valve does not switch, replace the valve.</p> <hr/> <p>↳ 1.1.3 Check the pressure hose.</p> <p>The pressure hose from the solenoid valve to fan has no kinks or leaks → see 1.1.4</p> <p>→ In the case of leaks in the hose, the hose needs to be replaced.</p> <p>→ When the air intake assembly on the fan is leaking, an appropriate seal kit must be ordered.</p> <hr/> <p>↳ 1.1.4 Mechanical failure.</p> <p>If all the above conditions are met and the blades do not rotate, then the trouble is a mechanical error. The fan must be sent to the manufacturer for testing.</p>

Error	Cause of error	Troubleshooting
<p>2 Blades do not return from the cleaning position to the cooling mode</p>	<p>→ 2.1 Fan speed is too high</p>	<p>→ 2.1.1 Reduce the speed.</p> <hr/> <p>↳ 2.1.2 Install more springs, if possible Additional springs increase the release force. The fan must be sent to the manufacturer.</p>
	<p>↳ 2.2 Oil in the fan does not flow back</p>	<p>→ 2.2.1 Check the pressure hose  The pressure hose from the solenoid valve to fan has no kinks or pinched positions → see 2.2.2</p> <hr/> <p>↳ 2.2.2 Check the functioning of the solenoid valve.  If necessary, connect external power supply. (Please note: voltage 12 V or 24 V only)  Solenoid valve switches (soft clicking) → see 2.2.3</p> <p>→ If the solenoid valve does not switch, replace the valve.</p> <hr/> <p>↳ 2.2.3 Mechanical failure.  If the fan with hose disconnected does not turn back in the idle state, there is a mechanical failure. The fan must be sent to the manufacturer for testing.</p>

## 11 Troubleshooting (electronic components)



### Perform system check

If several error causes occur at the same time, the LED lights up permanently red. In this case, the detailed cause of the error can no longer be assessed. For a detailed error cause, the electrical component must be connected to the Cleanfix control App. A system check can be performed via the Cleanfix control App. The result of the system check can be saved and retrieved as a PDF or transmitted to the manufacturer.

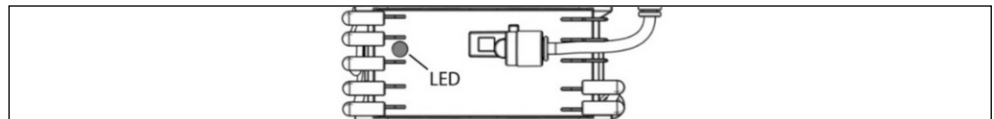









Fig. 70

LED error code	Cause of error
 Does not flash	Check the operating voltage
Green LED error code	Cause of error
 Permanently lit green	Normal status without Bluetooth connection
 Lit green for 3 sec.	Normal status with Bluetooth connection
 Permanently flashing green quickly	[automatic mode] paused <ul style="list-style-type: none"> <li>➤ In the Cleanfix control app, tap the [▶ resume] button to resume [automatic mode] (see section 8.6).</li> </ul>
Red LED error code	Cause of error
 Flashing red 1x	Air filter status is below 10% <ul style="list-style-type: none"> <li>➤ Pair the device with the Cleanfix control app.</li> <li>➤ Follow the instructions in the app (see section 8.8).</li> </ul>
 Flashing red 2x	Increased temperature <ul style="list-style-type: none"> <li>➤ Pair the device with the Cleanfix control app.</li> <li>➤ Acknowledge the error message in the app.</li> </ul> The service life of the device is impaired at a temperature of 65° or higher. <ul style="list-style-type: none"> <li>➤ If necessary, change the installation position of the device.</li> </ul>

 <p>Flashing red 3x</p>	<p>The pressure sensor values are faulty</p> <ul style="list-style-type: none"> <li>➤ Pair the device with the Cleanfix control app.</li> <li>➤ Restart the device in the device settings.</li> <li>➤ If the error persists, contact the manufacturer.</li> </ul> <p>Service address: See section 1.1.2</p>
 <p>Flashing red 4x</p>	<p>Short circuit, excess temperature, or broken valve cable</p> <ul style="list-style-type: none"> <li>➤ Turn the ignition off and on.</li> <li>➤ If the error persists, contact the manufacturer.</li> </ul> <p>Service address: See section 1.1.2</p>
 <p>Flashing red 5x</p>	<p>Short circuit or broken compressor cable</p> <ul style="list-style-type: none"> <li>➤ Turn the ignition off and on.</li> <li>➤ If the error persists, contact the manufacturer.</li> </ul> <p>Service address: See section 1.1.2</p>
 <p>Permanently flashing red</p>	<p>Critical temperature / temperature shutdown</p> <p>The device switches off at a critical temperature. When the device has cooled off, it switches on again.</p> <ul style="list-style-type: none"> <li>➤ If the error occurs repeatedly, move the device to a cooler location.</li> </ul>
 <p>Permanently flashing red quickly</p>	<p>Short circuit in the push button in the driver's cab or the pressure switch</p> <ul style="list-style-type: none"> <li>➤ Turn the ignition off and on.</li> <li>➤ If the error persists, contact the manufacturer.</li> </ul> <p>Service address: See section 1.1.2</p>
 <p>Permanently lit red</p>	<p>Multiple error messages present</p> <ul style="list-style-type: none"> <li>➤ Pair the device with the Cleanfix control app to call up all error messages.</li> </ul>

Red/green LED error code	Cause of error
 <p>Permanently flashing alternately red and green</p>	<p>Faulty memory readout</p> <ul style="list-style-type: none"> <li>➤ Contact the manufacturer.</li> </ul> <p>Service address: See section 1.1.2</p>

