

CLEANFIX®

CLEANFIX KIT FOR JOHN DEERE 6145R / 6155R / 6175R / 6195R / 6215R manufactured 2018 and later

Operating instructions

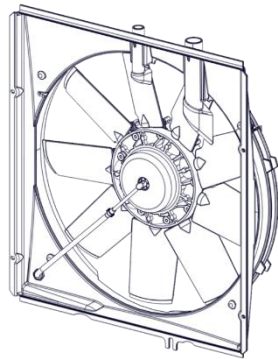

<https://cleanfix.org/instructions-jd>

- EN: Scan QR code to get instructions in other languages.
DE: QR-Code scannen um Anleitung in weiteren Sprachen zu erhalten.
FR: Scanner le code QR pour obtenir des instructions dans d'autres langues.
IT: Scansione QR-Code per ottenere istruzioni in altre lingue.
ES: Escanea el Código QR para obtener instrucciones en otros idiomas.
PT: Digitalize o Código QR para obter instruções noutras línguas.
TR: Diğer dillerdeki talimatlar için QR kodunu tarayın.



Contents

1	General information	4
1.1	Legal notice	4
1.1.1	Copyright.....	4
1.1.2	Manufacturer and service address.....	4
1.2	Introduction	5
1.2.1	Target group of these operating instructions.....	5
1.2.2	Liability and damages.....	5
1.2.3	Validity	6
1.2.4	Product identification	6
2	Safety	7
2.1	Intended use.....	7
2.2	Other regulations.....	7
2.3	Warning messages.....	7
3	Required tools.....	10
4	Removing the manufacturer's components.....	11
5	Installing the Cleanfix® fan components	12
5.1	Installing the Cleanfix® flange	12
5.3	Checking the flange axial and radial circular runout.....	13
5.4	Attaching the pressure hose to the fan	14
5.5	Installing the Cleanfix® reversible fan and fan shroud	15
5.6	Checking the smooth movement of the Cleanfix® reversible fan	19
6	Installing the Cleanfix® electrical components	21
6.1	Cleanfix® valve unit / for vehicles with a compressed air system	22
6.1.1	Installing the tee and overflow valve	23
6.1.2	Installing the Cleanfix® valve	24
6.1.3	Connecting the pressure hose to the overflow valve and the Cleanfix® valve	25
6.1.4	Installing the switch	27
6.1.5	Connecting the Cleanfix® valve and switch to the vehicle's power supply	29

6.1.6	Running the pressure hose of the Cleanfix [®] reversible fan to the Cleanfix [®] valve	32
7	Switching off the Vistronic fan clutch	35
8	Operation.....	36
8.1	Initial start-up.....	36
8.2	Cleanfix [®] valve / for vehicles with a compressed air system	36
8.3	Cleanfix [®] control unit with minitimer / for vehicles without a compressed air system.....	36
9	Maintenance	37
9.1	Servicing the Cleanfix [®] reversible fan	37
9.2	Servicing the Cleanfix [®] electrical components	37
10	Troubleshooting.....	38
10.1	Troubleshooting Cleanfix [®] reversible fans	38

1 General information

1.1 Legal notice

1.1.1 Copyright

The copyright is owned by Hägele GmbH, Germany. Copies, incorporation in other media, translations, or the use of excerpt or parts is not permitted without the explicit consent of Hägele GmbH. All rights reserved.

1.1.2 Manufacturer and service address



Hägele GmbH

Am Niederfeld 13
73614 Schorndorf
Germany

Phone: +49 7181 96988-0
Fax: +49 7181 96988-80
E-mail: info@cleanfix.org
Website: <http://www.cleanfix.org>

Service:

Phone: +49 7181 96988-36
E-mail: service@cleanfix.org

For additional information, feel free to contact our customer service team and our worldwide representatives at any time.

1.2 Introduction

Before installing or operating the Cleanfix® Kit for John Deere, familiarize yourself with the contents of these operating instructions. This will help you achieve optimal results and work safely. The operating instructions are a component of the product and must always be close at hand. By doing so, you will:

- prevent accidents.
- comply with the warranty terms.

1.2.1 Target group of these operating instructions

These operating instructions are intended exclusively for mechanics trained on agricultural machinery.

The product may be installed and started up only by persons who are familiar with the operating instructions, the product, as well as the national laws and regulations concerning work, safety, and accident prevention.

1.2.2 Liability and damages

Since we are not included in technical service updates from the manufacturer, you may be required to make adjustments when installing this product. Hägele GmbH does not assume responsibility for installation and modification costs.

On account of the information provided in these operating instructions, the manufacturer accepts no liability for direct damages or indirect losses arising from improper operation or maintenance. We disclaim all liability for personal injury or property damage caused by untrained personnel or through failure to comply with regulations concerning work, safety, and accident prevention.

No claims for modification of products that have already been delivered may be made on the basis of the data, illustrations, and descriptions in these operating instructions.

For your safety, use only original spare parts and original accessories.

We assume no liability for the use of other products and any resulting damages.

- ▶ Inspect delivery for damage in transit and for completeness.
- ▶ Immediately document in writing any defects and damages.
- ▶ Photograph damaged components.
- ▶ Send in a written damage report.

1.2.3 Validity

These instructions contain information required for installing and starting up the product.

In addition to the description of the equipment, the instructions also contain some abstractions. The product features may therefore partially deviate from the descriptions and depictions.

1.2.4 Product identification

The following information is necessary for inquiries to the manufacturer:

(1) Fan serial number:

- On the side edge of the front housing

Serial number:

#						
---	--	--	--	--	--	--

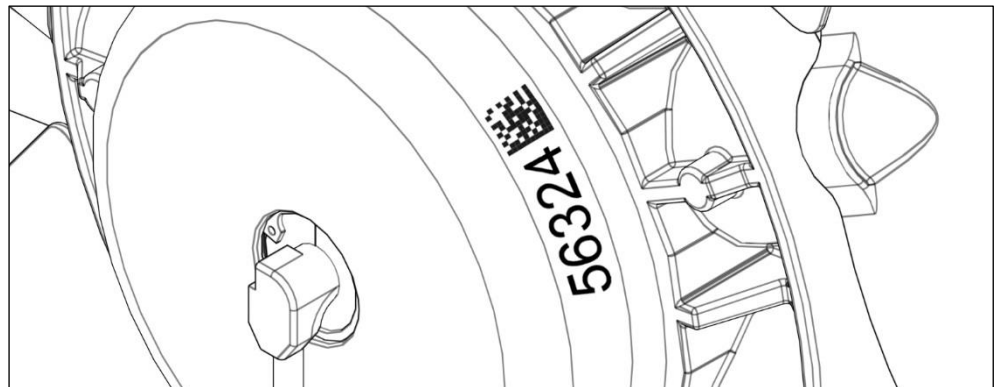

- Or on the top of the fan

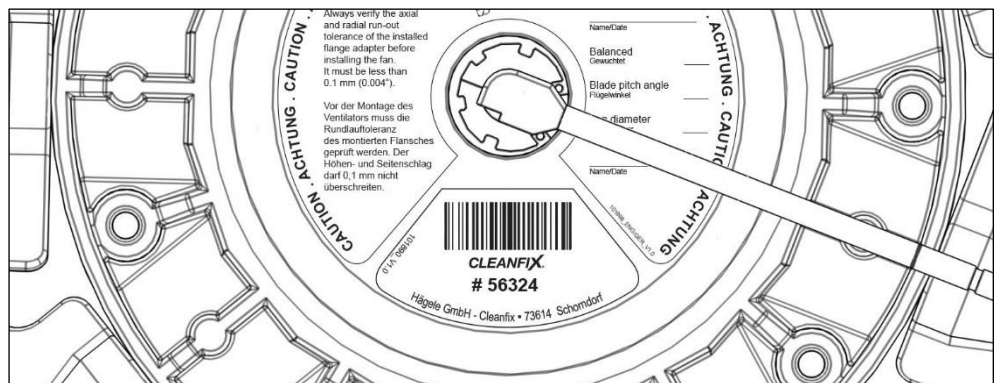

(2) Vehicle:

Manufacturer: _____

Model: _____

Operating hours: _____

(3) Photo of the fan:

2 Safety

This chapter provides general safety information. The individual chapters of the operating instructions also contain specific safety information that is not provided in the “Safety” chapter. Observe the safety information:

- for your own safety.
- for the safety of others.
- to ensure machine safety.

When commercial vehicles are involved, a number of risks can arise due to improper behavior. For this reason, work very carefully and never under time pressure.

2.1 Intended use

The product may be used only for the following purposes:

- For cooling commercial vehicles.
- For cleaning the fans of commercial vehicles

Only persons authorized by the manufacturer may make modifications, alterations, and repairs.

As a general principle, unauthorized modifications, alterations, or improper use exempt the manufacturer from liability for resulting damages.

2.2 Other regulations

In addition to these instructions, the respective national laws and regulations as amended must be observed (e.g., protective clothing, accident prevention regulations, and occupational health and environmental rules).

2.3 Warning messages

 **WARNING!**

Rolling of the vehicle may result in serious injury or death!

An unsecured vehicle can run over or crush you. This can result in serious injury or death.

- Turn off the vehicle.
- Remove the ignition key.
- Secure the vehicle against rolling.

Wearing loose-fitting work clothes may result in serious injury or death!

Do not wear loose-fitting clothes because they can become entangled in rotating parts.

- Wear work and protective clothing stipulated by the employer's liability insurance association.

Working on a machine while it is running may result in serious injury or death!

No work may be performed on the machine while it is running. Objects or persons may be caught, pulled in, or crushed.

- Work only on machines that have been turned off.

Modifications to the fan may result in serious injury or death!

Unauthorized modifications may impair the functioning and/or safety and the service life of the fan. Unauthorized modifications to the fan terminate the manufacturer's warranty and liability. This may result in damage to the machine as well as to serious injury or death.

- Absolutely no modifications may be made to the fan.

 CAUTION!

Failure to resolve malfunctions may result in accidents or damage!

Operation of a defective fan or fan component may lead to accidents or damage.

- Immediately stop the machine.
- Shut down the machine.
- Secure the machine.
- Resolve the fault promptly or engage a vehicle shop.

Activation of the reversing function while persons are standing in front of the vehicle may result in accidents!

The fan generates strong air currents when it is in the cleaning position. Persons standing in front of the vehicle may be struck by flying dirt when the reversing function is activated.

- Make sure that no persons are standing in front of the vehicle.
-

Activation of the reversing function in closed rooms may result in accidents!

The fan generates strong air currents when it is in the cleaning position. In closed rooms, this may generate dust and result in damage or accidents due to flying parts.

- Use the reversing function only in a safe location and only outside of rooms.

Damage caused by lines or tubes that are too loose or are attached to moving parts!

During travel, the installed lines and tubes are subjected to vibrations. As a result, lines or nearby parts may be damaged due to friction.

- All lines and tubes must be securely fastened and must not make contact with moving parts.

NOTE

Property damage may result if the fan is installed directly on the crankshaft or when the fan is driven by a spur gear!

Torsional vibrations from the crankshaft or the spur gear will damage the fan and may cause damage to the vehicle.

- Install Cleanfix[®] vibration dampers between the fan and the crankshaft or the spur gear.

Reversing the fan while the vehicle is in the red temperature range may result in property damage!

The cooling effect is interrupted when the reversing function is activated. Reversing the fan while the vehicle is in the red temperature range causes the engine to overheat.

- Avoid reversing the fan while the vehicle is in the red temperature range.
 - Park the vehicle and open the hood so that the vehicle can cool down.
-

3 Required tools

Flange installation

- Magnetic or clamp type dial gauge
- 45 Nm torque wrench

Fan installation

- 20 Nm torque wrench
- Locking pliers
- Standard tools

Pressure hose installation and connection

- Grease
- Pincers
- Standard tools for pressure hose fitting

Electrical component installation and connection

- Standard electrical and hand tools

4 Removing the manufacturer's components

CAUTION!

Risk of injury due to the hot engine!

A hot engine can burn hands or other body parts

- Turn off the engine.
 - Allow the engine to cool down.
 - Remove the ignition key.
 - Disconnect the battery.
-
- ▶ Remove the fan guard and safety components as needed to gain access to the installed fan.
 - ▶ Loosen any belts that drive the fan pulley.
 - ▶ Remove the fan and fan shroud.
 - ▶ Remove the stud bolts.



5 Installing the Cleanfix® fan components

5.1 Installing the Cleanfix® flange

- ▶ Clean the fan drive mounting surface for the flange to remove all dirt and rust.
- ▶ Attach the flange to the fan drive using the four supplied M10x55 pan head screws.
- ▶ Tighten pan head screws to 45 Nm.



5.3 Checking the flange axial and radial circular runout

⚠ WARNING!

Property damage due to axial and radial circular runout!

Imbalances damage the fan and may result in vehicle damage and serious injury.

- The axial and radial circular runout must be checked using a dial gauge and must not exceed 0.1 mm (0.004").
 - Check the fan drive mounting surface and the flange for contamination and clean accordingly.
 - If necessary, rotate the flange to the next hole and install and measure again.
-
- ▶ Loosen any belts that drive the fan pulley. This will allow for a more accurate axial and radial circular runout measurement.
 - ▶ Check the axial and radial circular runout using a dial gauge. The axial and radial circular runout must not exceed 0.1 mm (0.004").

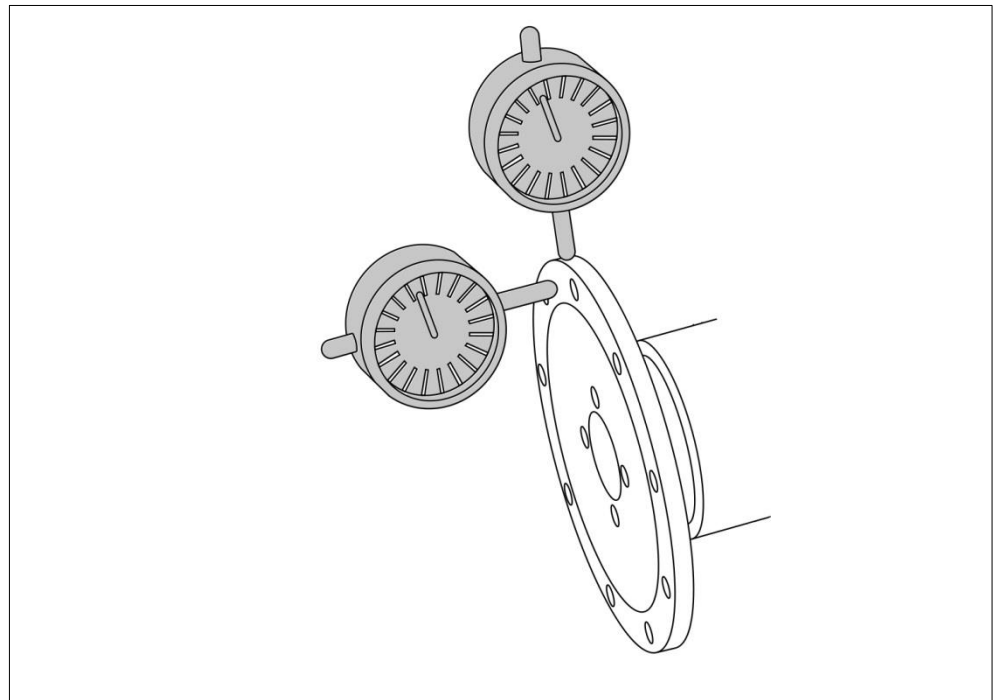

5.4 Attaching the pressure hose to the fan

NOTE

Property damage due to bending of the air intake tube!

If the air intake tube of the air intake assembly is bent down toward the blades during installation, the fan blades will hit the hose during operation.

- Manually bend the air intake tube of the air intake assembly into the original position.

Collision due to incorrectly installed hose clamp!

The hose clamp must be parallel to the fan as pictured. If the ears of the hose clamp point up and down, the fan blades can hit the hose clamp during operation.

- Rotate the hose clamp using pliers.

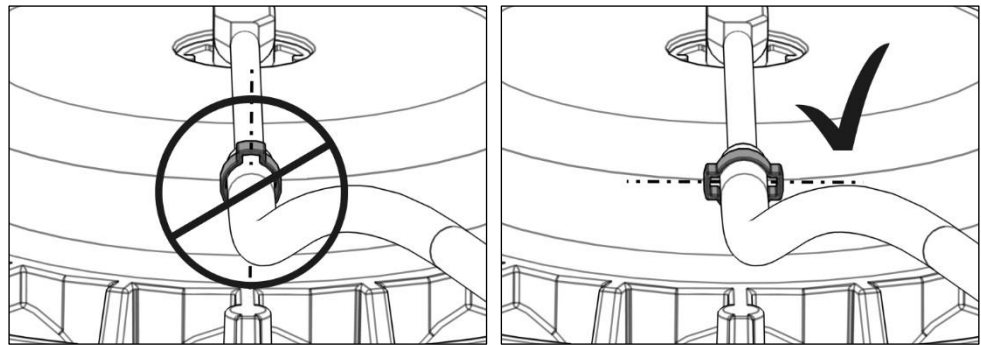

- ▶ Apply a thin layer of lubricant to the end of the air intake tube to make it easier to slide the pressure hose over the air intake tube.
- ▶ Slide the hose clamp over the pressure hose.
- ▶ Slide the pressure hose up to the side marks (25 mm; 1") on the air intake tube of the air intake assembly.
- ▶ Position the hose clamp as shown in the picture.
- ▶ Secure the pressure hose by pinching the ears of the hose clamp with pincers.

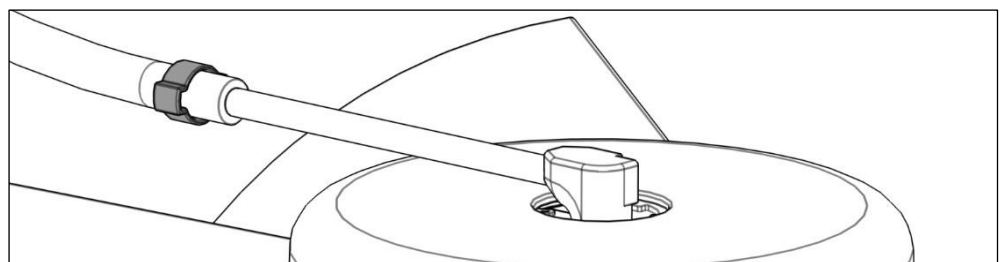

5.5 Installing the Cleanfix® reversible fan and fan shroud

- ▶ Attach the supplied hose screw connection.

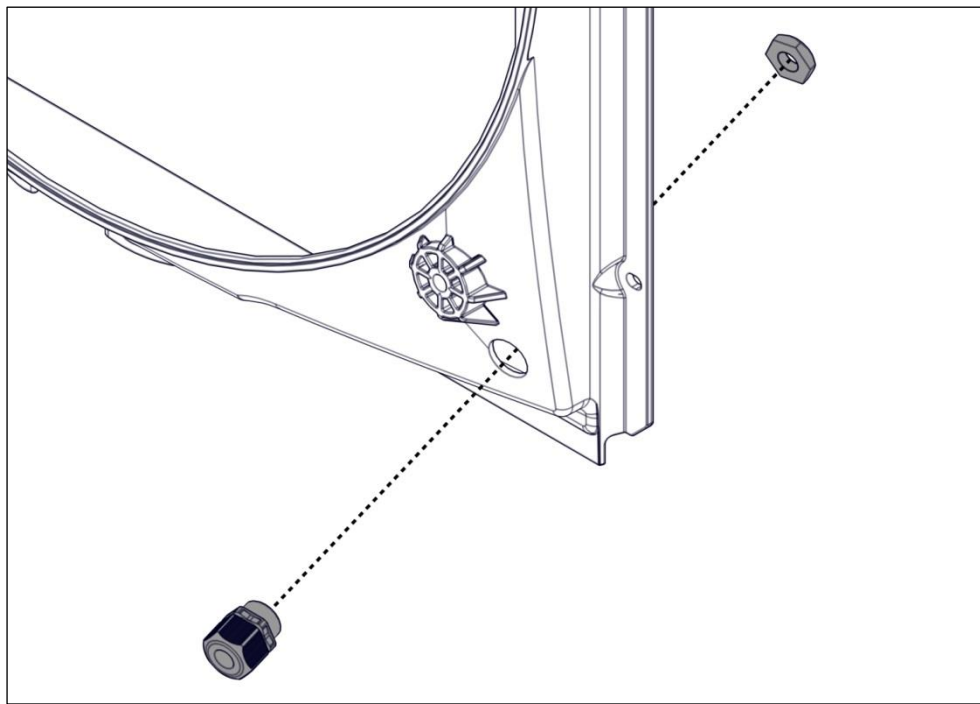

- ▶ Hang the supplied ring over the flange so that you can mount it more easily later.

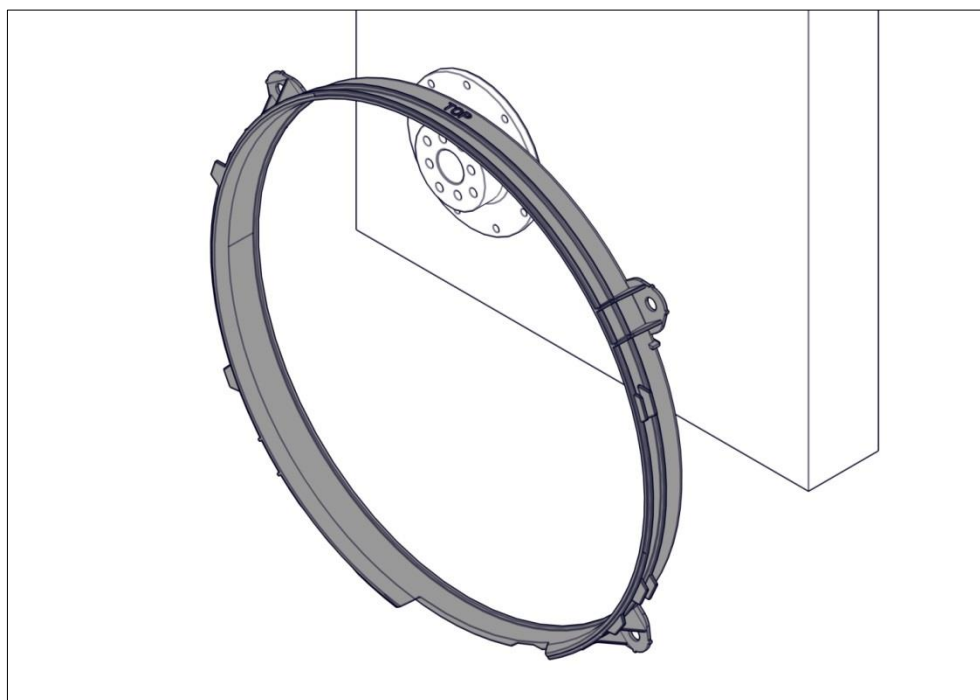

- ▶ Attach the supplied fan shroud to the radiator.

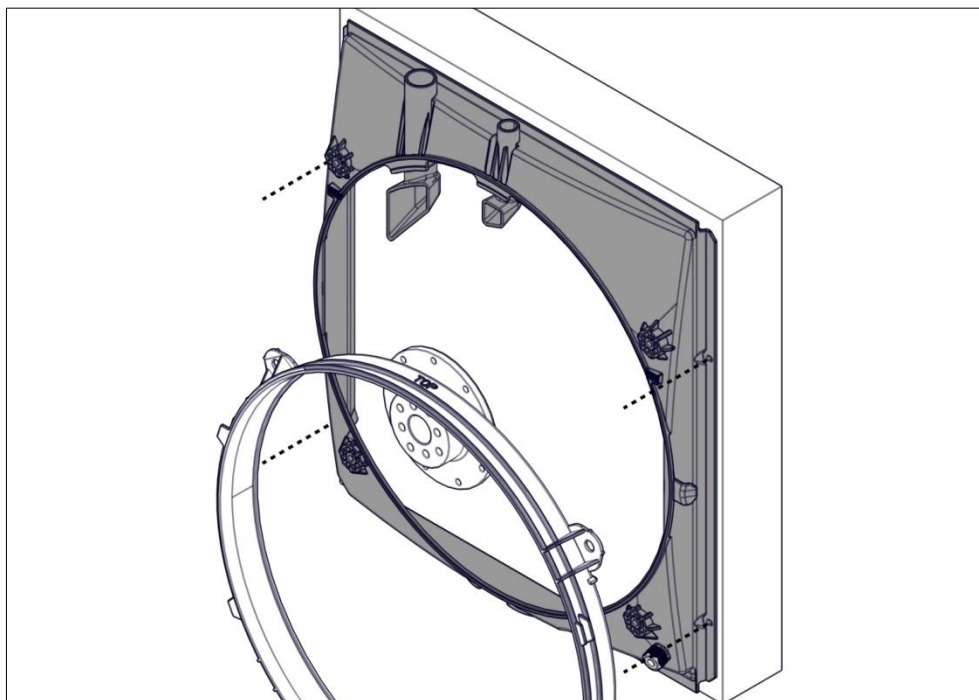

- ▶ Attach the Cleanfix® reversible fan to the flange using the supplied locking screws.
- ▶ Tighten the locking screws to 20 Nm.

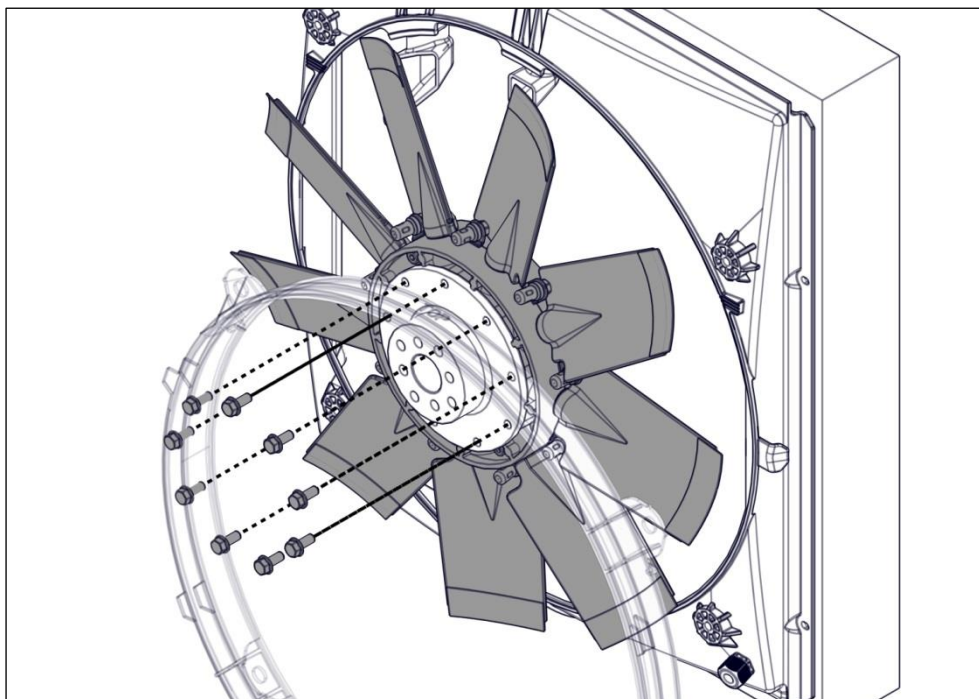

- ▶ Mount the ring using the supplied screws and washers. Make sure that the ring is centered on the fan.

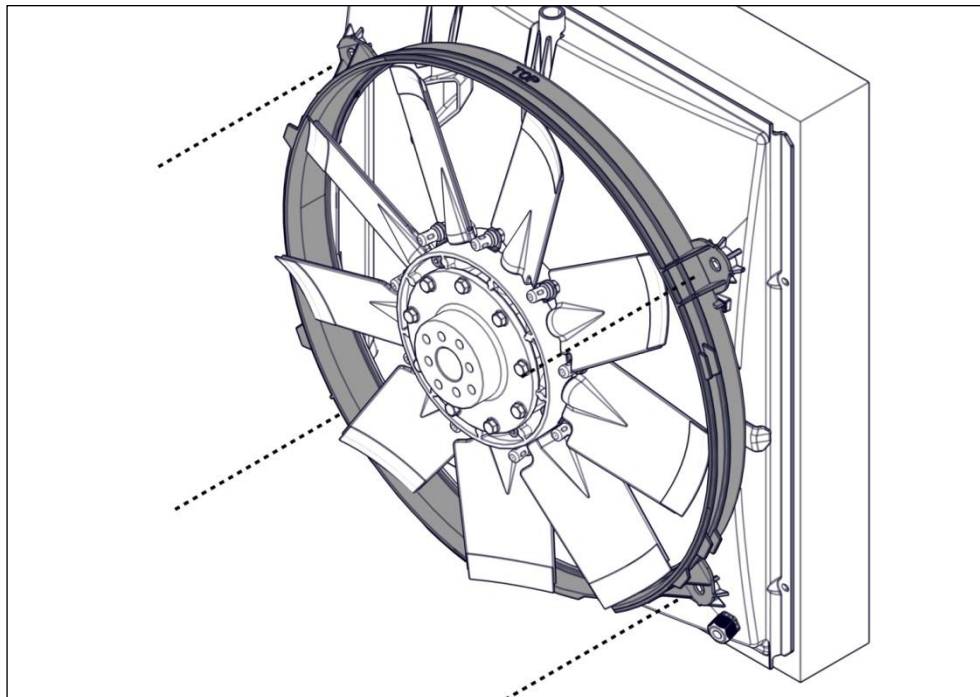

- ▶ Guide the pressure hose from the inside of the shroud through the hose screw connection.

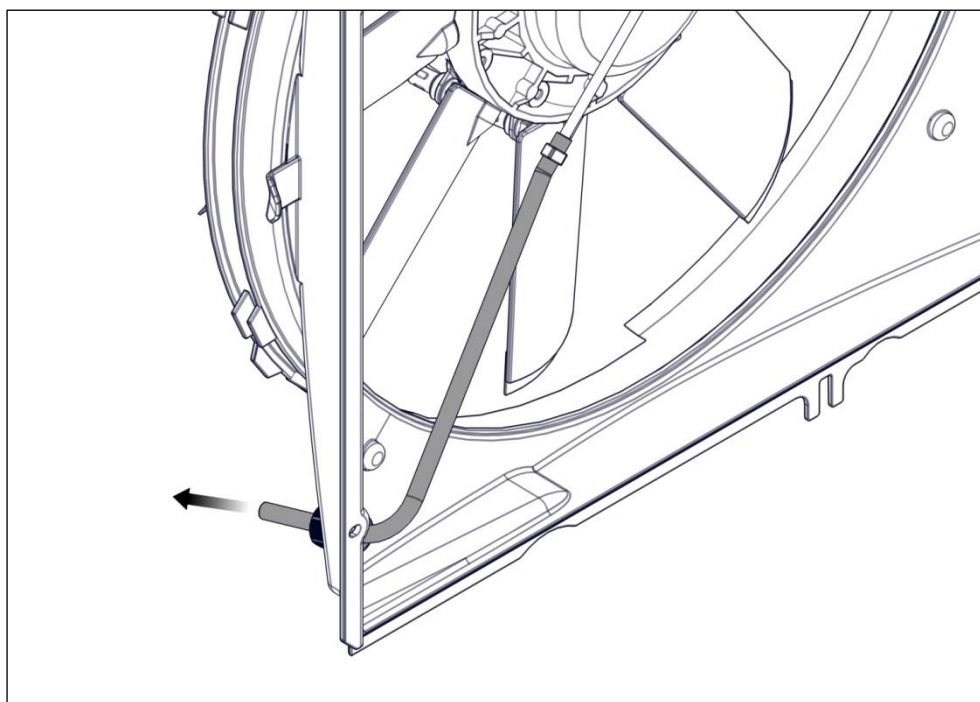

NOTE**Property damage due to excessive tension on the pressure hose!**

If the air intake assembly on the fan is under tension from the hose, the seals on the air intake assembly will wear out and the fan will start leaking.

- If necessary, open the hose screw connection, adjust the hose tension, and close the hose screw connection again.

- ▶ Pull the pressure hose through the hose screw connection so that it does not catch on the blades.
- ▶ Make sure that the pressure hose is not kinked behind the hose screw connection.
- ▶ Secure the hose with the compression nut of the hose screw connection.

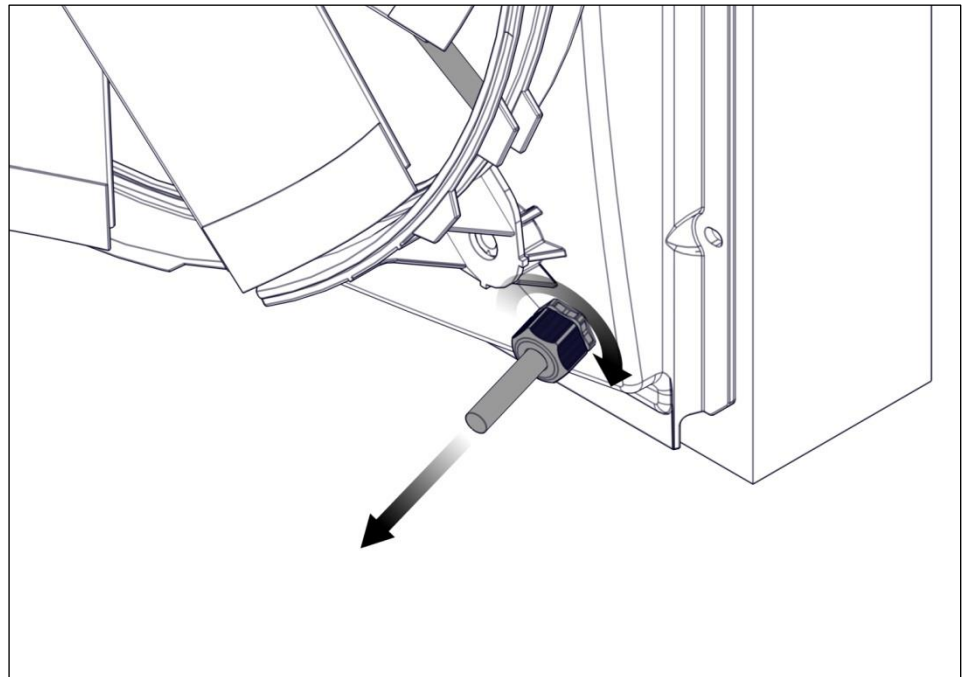

5.6 Checking the smooth movement of the Cleanfix® reversible fan

- ▶ Supply compressed air (max. 10 bar or 140 psi) to the fan until the blades turn to their cross position.
- ▶ Use locking pliers to pinch the pressure hose, which will trap the air in the system.
- ▶ Remove the pressure hose from the compressed air supply.

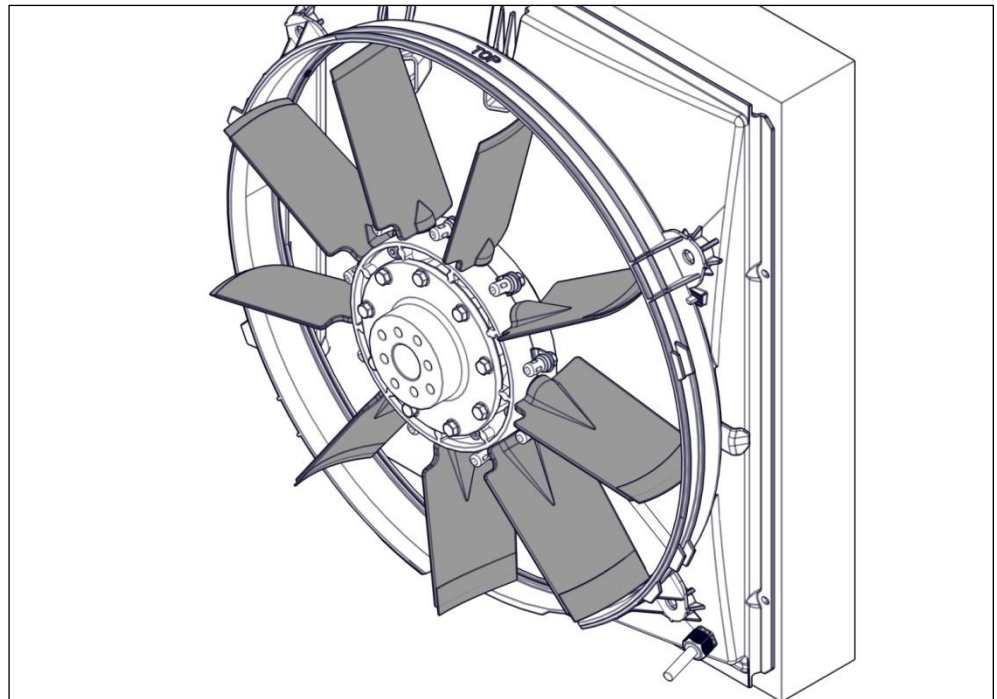

NOTE

Property damage due to rotation of the fan with tight drive belts!

Rotation of the fan with tight belts results in excessive force and may result in damage to the fan and drive.

- Loosen the drive belts.

- ▶ Manually rotate the fan.
- ▶ Make sure that the blades do not come into contact with any objects.
- ▶ Make adjustments as needed.

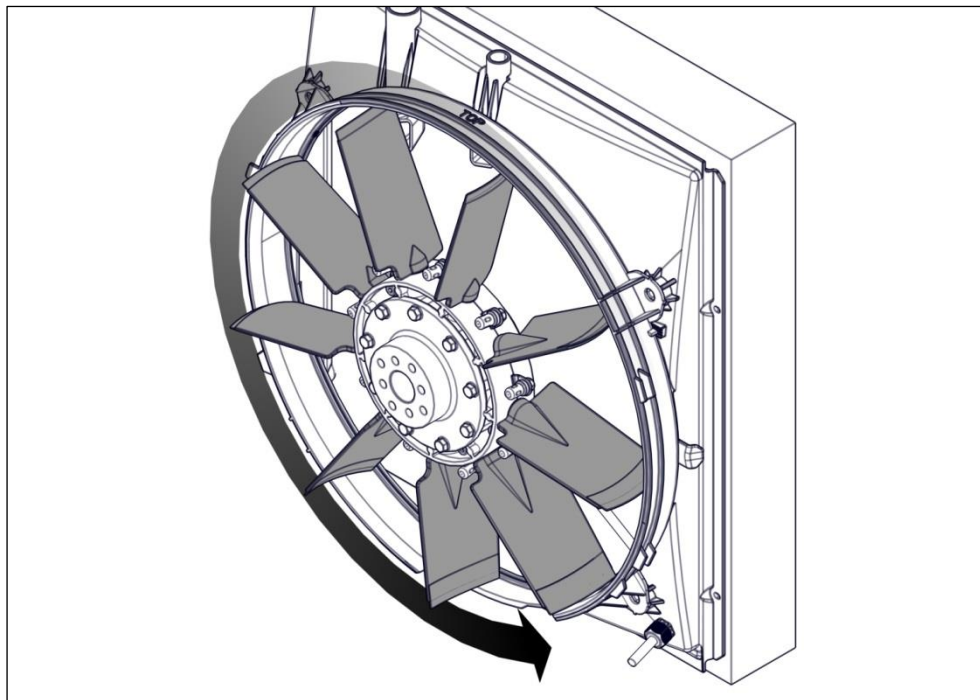

- ▶ Remove the locking pliers.

⚠ WARNING!**Pulling in of loose objects!**

Loose objects can be pulled into the fan during operation, which may result in damage to the fan and vehicle and cause serious injury!

- Remove loose objects or secure them with plastic ties.

6 Installing the Cleanfix® electrical components

CAUTION!

Damage caused by lines or tubes that are too loose or are attached to moving parts!

During travel, the installed lines and tubes are subjected to vibrations. As a result, lines or nearby parts may be damaged due to friction.

- All lines and tubes must be securely fastened and must not make contact with moving parts.

Overview of the Cleanfix® electrical components

The Cleanfix® electrical components are installed as described in the following sections. The relevant section must be taken into account depending on the delivered version.

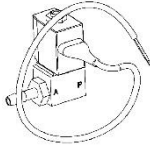
	For vehicles with a compressed air system
Cleanfix® electrical component	Valve → For installation, see section 6.1 
Reversing function	Switch Press the switch to change from cooling to cleaning. The fan remains in cleaning mode for as long as the switch is pressed.

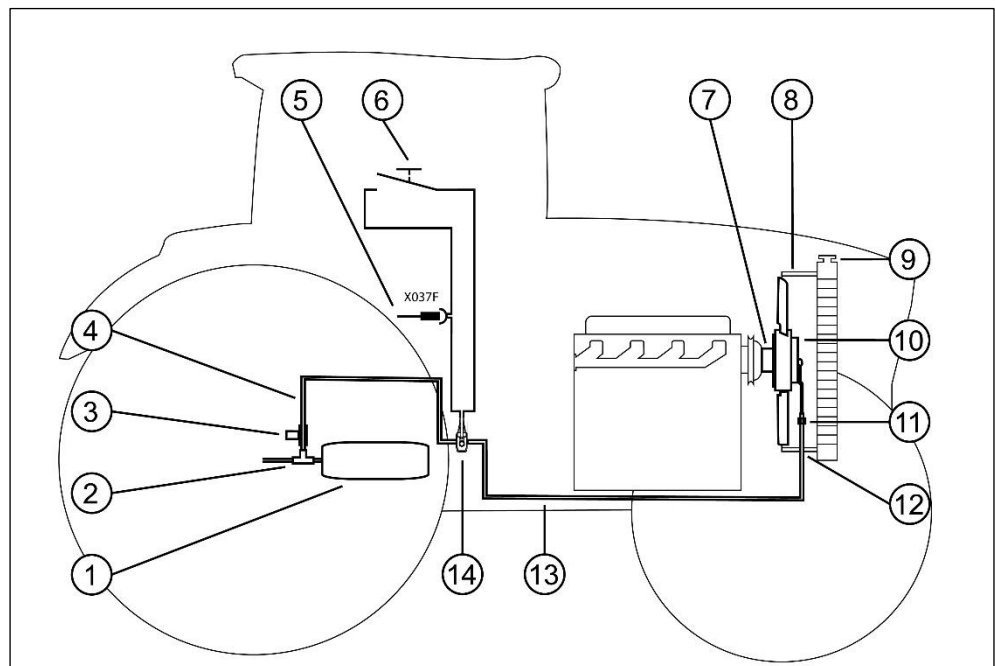
6.1 Cleanfix® valve unit / for vehicles with a compressed air system

- (1) Compressed air reservoir
- (2) Tee
- (3) Overflow valve (min. 6.5 bar or 94 psi, max. 7.0 bar or 102 psi)
- (4) Pressure hose
- (5) 3-pole outlet in the control console
- (6) Switch (momentary rocker switch)
- (7) Adapter flange
- (8) Fan shroud
- (9) Radiator
- (10) Cleanfix® reversible fan (pneumatic)
- (11) Hose clamp
- (12) Hose screw connection
- (13) Pressure hose (fuel line)
- (14) Cleanfix® valve unit

6.1.1 Installing the tee and overflow valve

- ▶ Remove the right rear wheel to access the vehicle's compressed air supply.



- ▶ Remove the compressed air tube from the compressed air reservoir.
- ▶ Mount the tee on the compressed air reservoir.
- ▶ Shorten the compressed air tube as needed and reconnect it to the compressed air reservoir via the tee.
- ▶ Connect the overflow valve to the arm of the tee.
- ▶ Align the tee and overflow valve and screw down the connections.

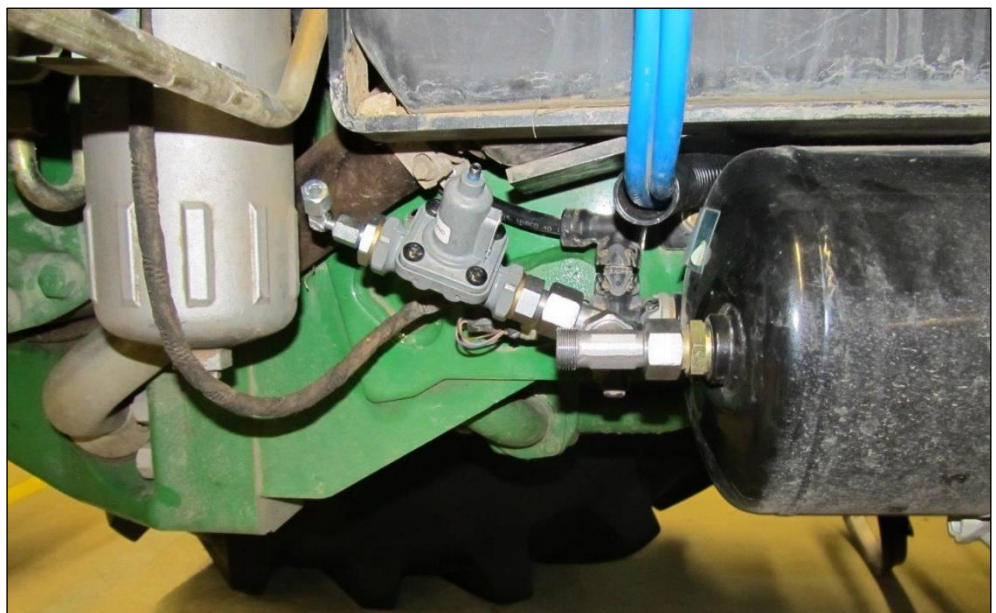

6.1.2 Installing the Cleanfix® valve

- ▶ Drill an 8 mm (0.32") hole below the flap on the step, as pictured.



- ▶ Cut the pressure hose of the Cleanfix® fan to a suitable length.
- ▶ Connect the pressure hose to connector A of the Cleanfix® valve.
- ▶ Use the supplied rubber pipe clamp, screw, and nut to attach the Cleanfix® valve to the inside of the flap.



6.1.3 Connecting the pressure hose to the overflow valve and the Cleanfix® valve

- ▶ Connect the pressure hose with corrugated tube to the overflow valve.

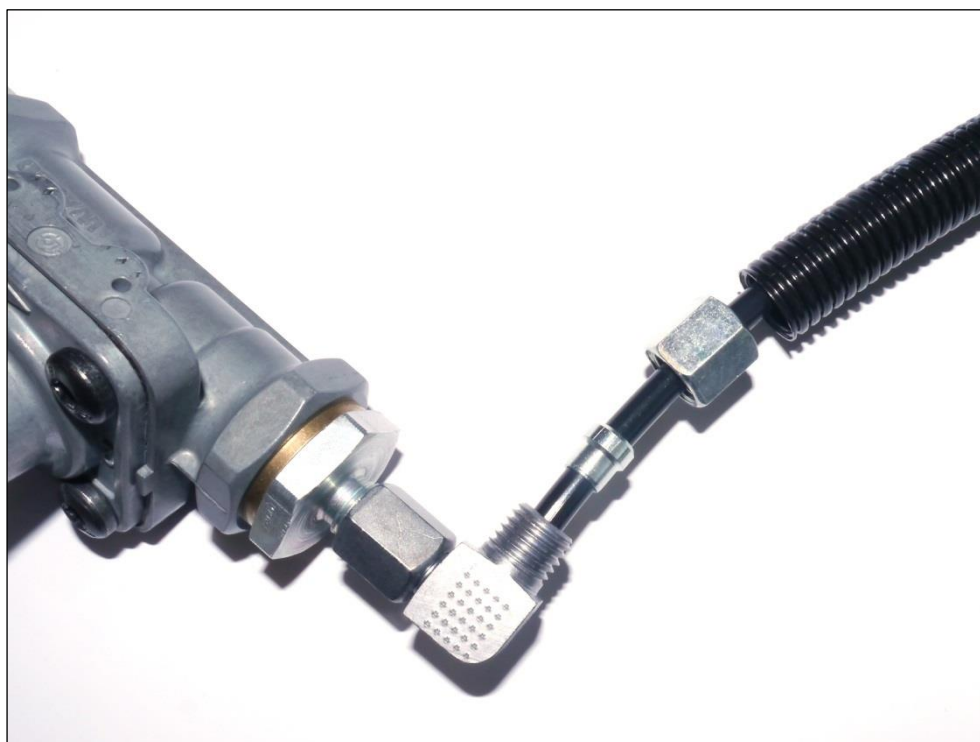

- ▶ Run the pressure hose with corrugated tube as pictured.
- ▶ Connect the pressure hose to connector P of the Cleanfix® valve.

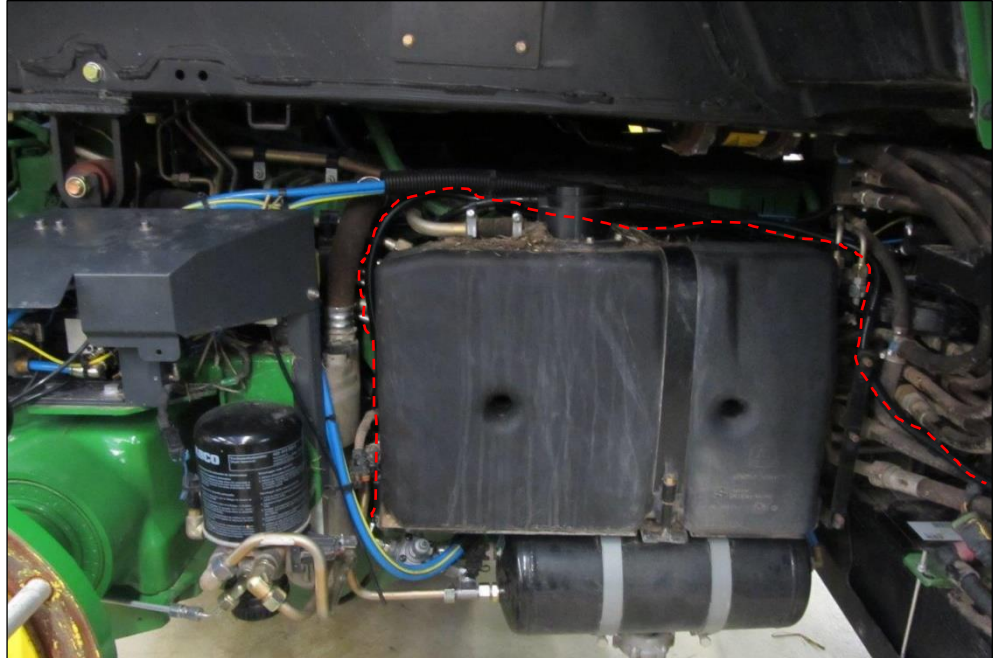
**NOTE**

Property damage due to contact of the corrugated tube with hot pipes!

- The minimum clearance of 10 mm (0.4") to other cables and tubes must be observed.
-
- ▶ Use the supplied rotatable corrugated tube holders to attach the corrugated tube to adjacent cables or tubes.

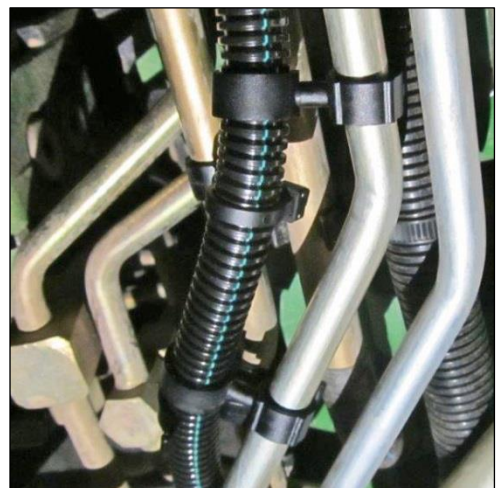

6.1.4 Installing the switch

Installation location: side console

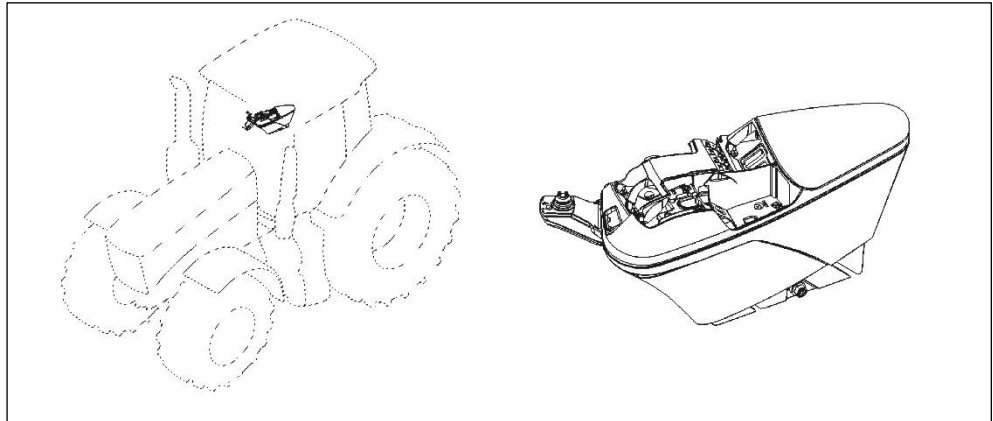

- ▶ Remove the screws (A) from the connector holder.
- ▶ Carefully lift out the connector holder.

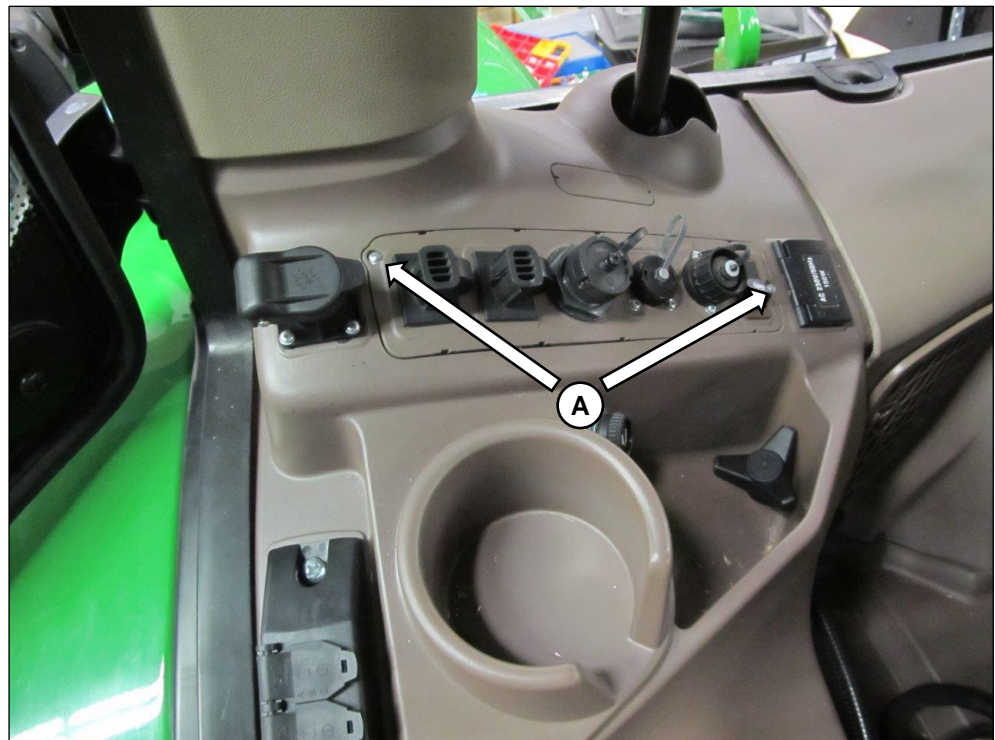

- ▶ Lift out and remove the cover plate for the switch from the connector holder.



- ▶ Remove the screws on the socket.
- ▶ Lift out the socket.

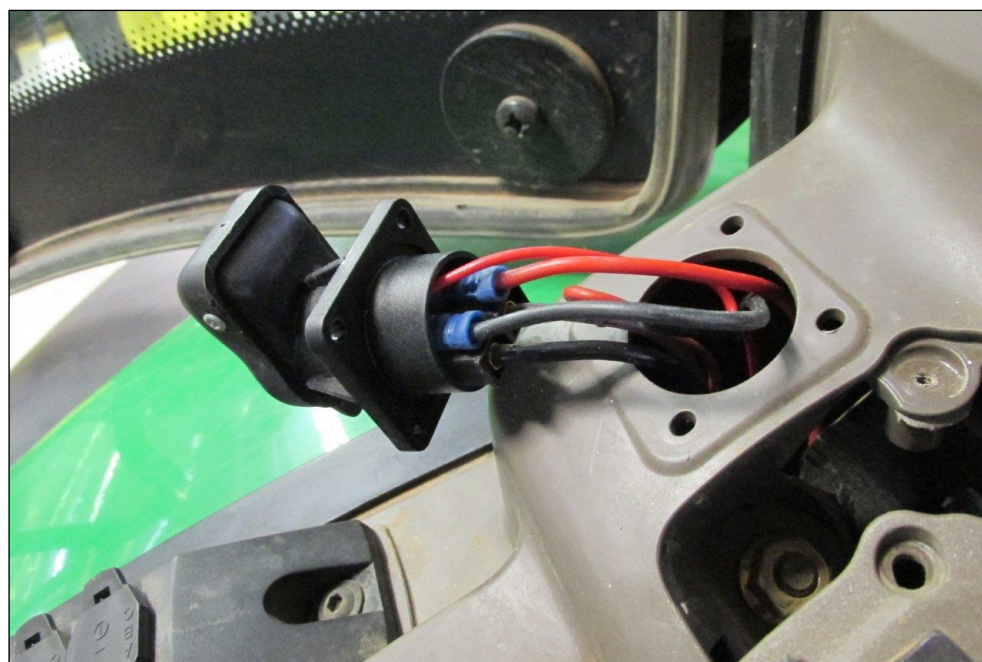

6.1.5 Connecting the Cleanfix® valve and switch to the vehicle's power supply

⚠ CAUTION!

Damage caused by lines or tubes that are too loose or are attached to moving parts!

During travel, the installed lines and tubes are subjected to vibrations. As a result, lines or nearby parts may be damaged due to friction.

- All lines and tubes must be securely fastened and must not make contact with moving parts.

- ▶ Run the supplied cable harness between the valve and the driver's cab.

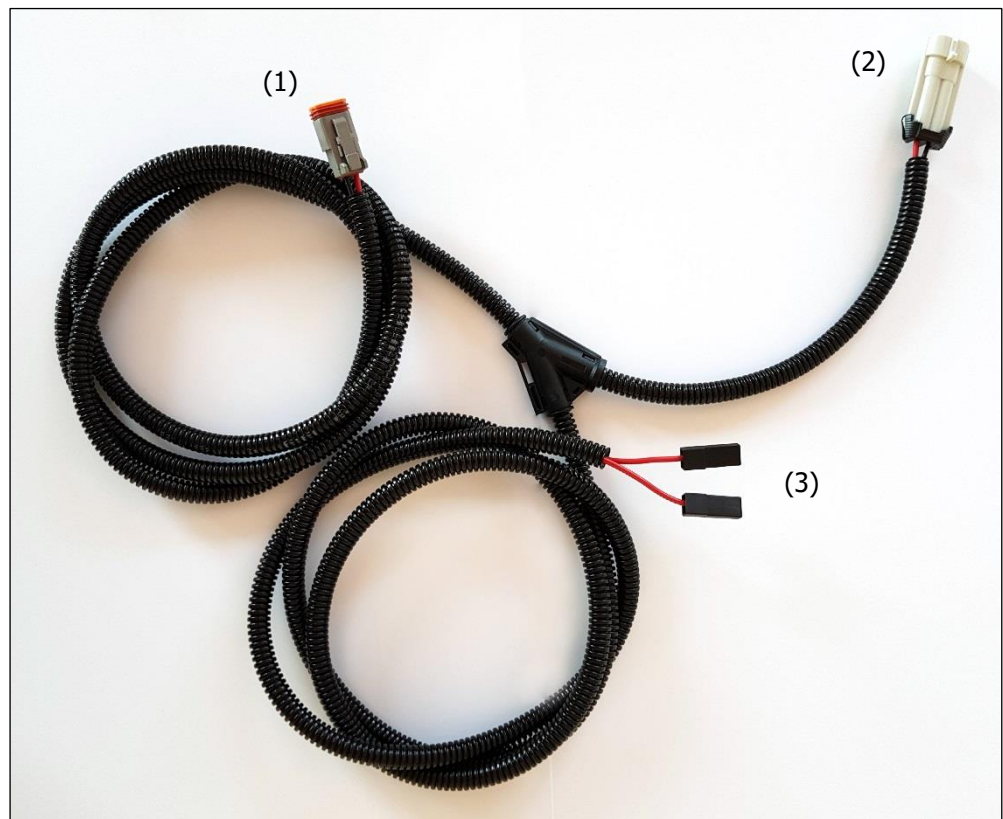

- (1) Connector for valve
- (2) Connector for X037F-3 plug in the side console at the lower right
- (3) Connector for switch

- ▶ Join the connectors of the valve and the cable harness.

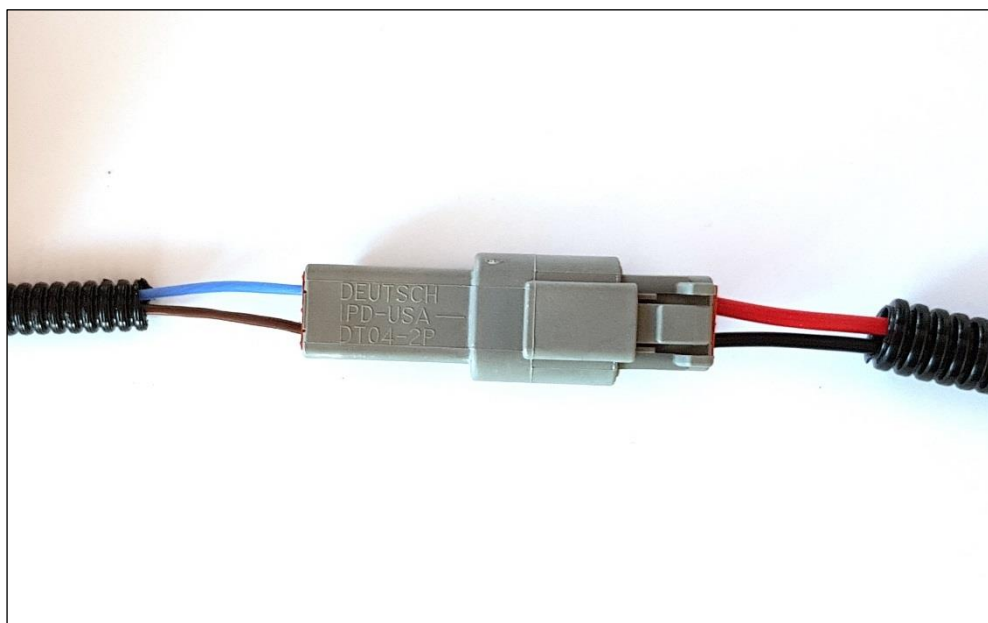

- ▶ Connect the cable harness to the X037F-3 plug (in the side console at the lower right).

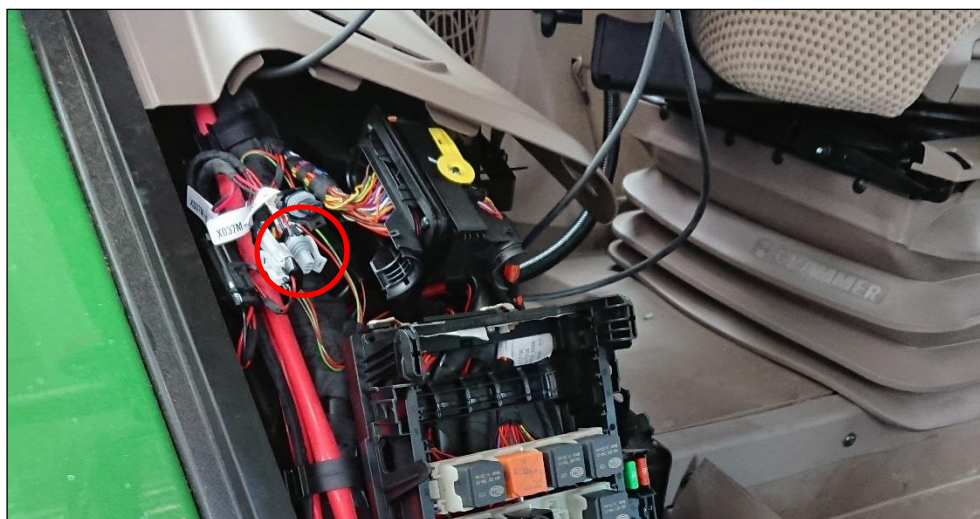

- ▶ Connect the switch to the cable harness and mount it in the connector holder.



- ▶ Reinstall the connector holder.
- ▶ Attach the Cleanfix label above the switch.



6.1.6 Running the pressure hose of the Cleanfix® reversible fan to the Cleanfix® valve

- ▶ Run the corrugated tube with the pressure hose as pictured.

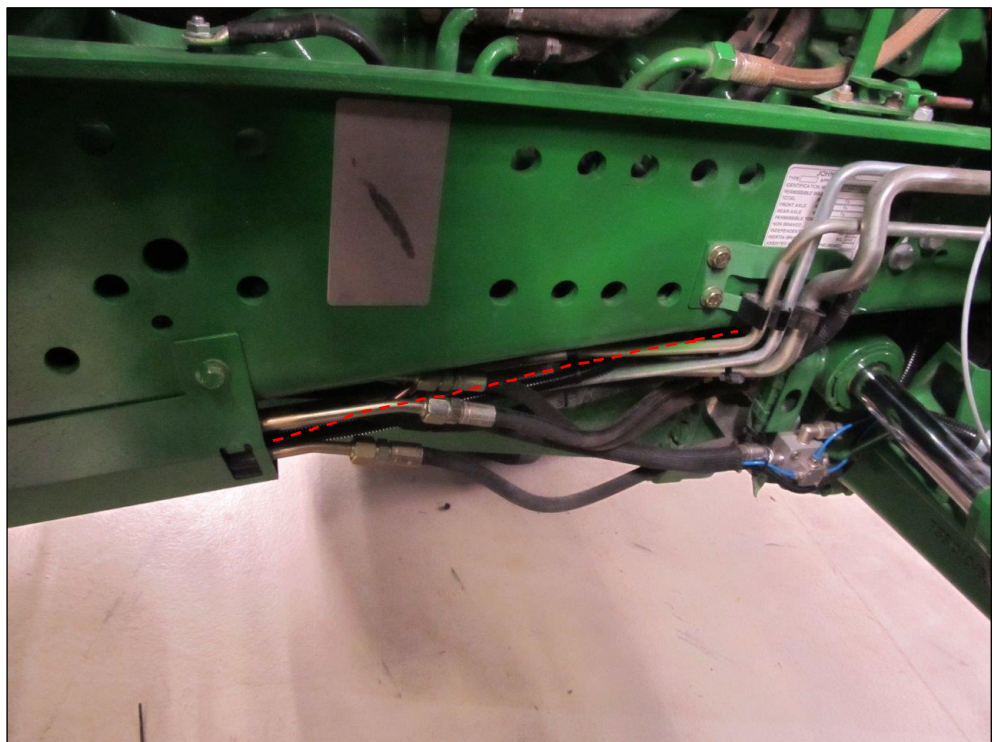

NOTE**Property damage due to contact of the corrugated tube with hot pipes!**

- The minimum clearance of 10 mm (0.4") to other cables and tubes must be observed.
-
- ▶ Use the two supplied rubber pipe clamps to attach the corrugated tube with pressure hose running near the fan shroud to the bracket.

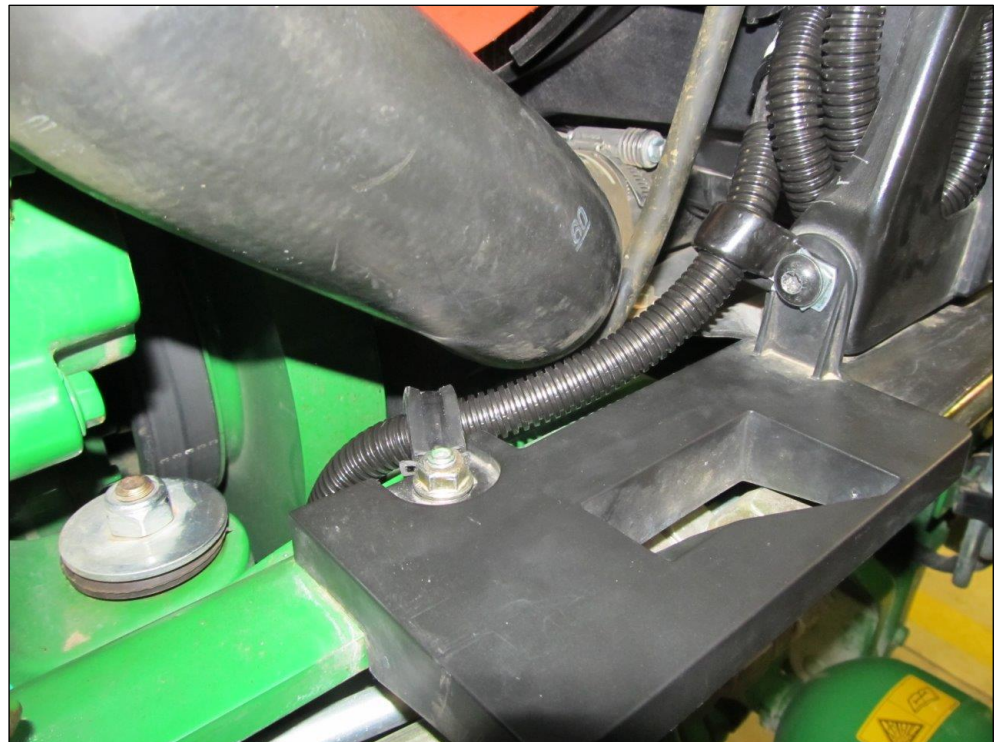

- ▶ Use the supplied rotatable corrugated tube holders to attach the corrugated tube with pressure hose to adjacent cables or pipes.

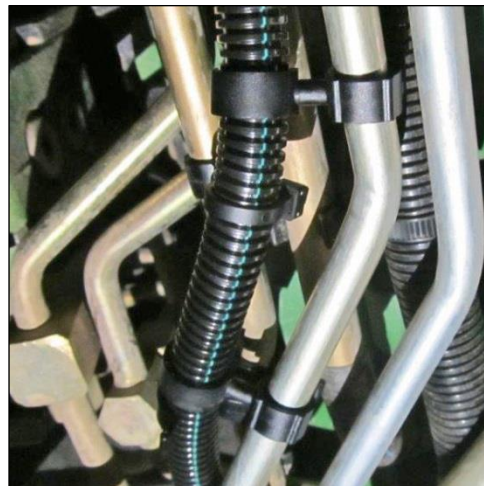

7 Switching off the Vistronic fan clutch

For models manufactured in 2018 and later, the Vistronic fan clutch must be switched off.

- ▶ Download the engine software using the Service Advisor.
- ▶ Start programming the engine software.

A dialog box with the following text appears:

“If an electronically controlled main fan clutch is installed, box must be checked. If it is not installed, box must be un-checked.”

- ▶ Clear the check box below this text.

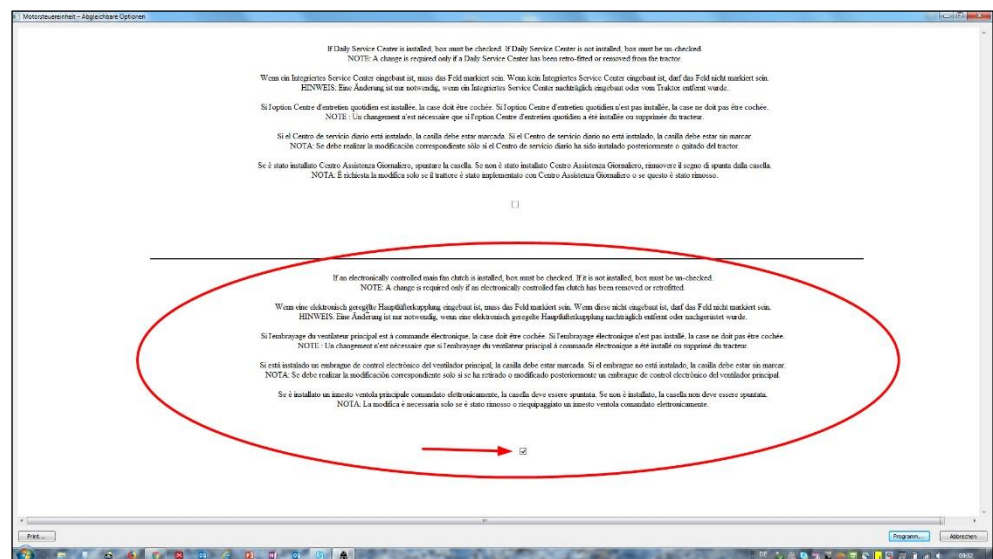

- ▶ Continue programming.

8 Operation

8.1 Initial start-up

The first time you start up the fan, reverse it three times in neutral, and then you can reverse it at higher speeds.

8.2 Cleanfix® valve / for vehicles with a compressed air system

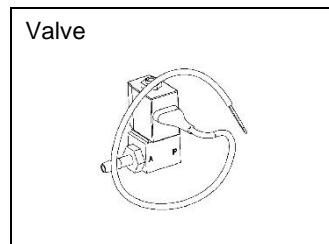

Press the switch to change from cooling to cleaning. The fan remains in cleaning mode for as long as the switch is pressed.

8.3 Cleanfix® control unit with minitimer / for vehicles without a compressed air system

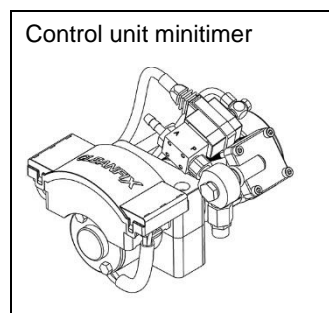

Briefly press the switch to automatically change from cooling to cleaning and back again.

9 Maintenance

9.1 Servicing the Cleanfix[®] reversible fan

Cleanfix[®] reversible fans are maintenance-free.

9.2 Servicing the Cleanfix[®] electrical components

Cleanfix[®] valve units are maintenance-free.

10 Troubleshooting

10.1 Troubleshooting Cleanfix® reversible fans

Error	Cause of error	Troubleshooting
1 Blades do not rotate to the cleaning position	<p>→ 1.1 No or low compressed air supply (with a compressed air system)</p>	<p>→ 1.1.1 Check the compressed air supply at the solenoid valve.</p> <p>Compressed air supplied at the solenoid valve → see 1.1.2</p> <p>→ If no pressure is being applied to the solenoid valve, check the compressed air supply (min. 6.5 bar or 94 psi / max. 8 bar or 116 psi).</p> <hr/> <p>↳ 1.1.2 Check the functioning of the solenoid valve.</p> <p>If necessary, connect external power supply. (Please note: voltage 12 V or 24 V only)</p> <p>Solenoid valve switches (soft clicking) → see 1.1.3</p> <p>→ If the solenoid valve does not switch, replace the valve.</p> <hr/> <p>↳ 1.1.3 Check the pressure hose.</p> <p>If necessary, pull the pressure hose from the valve and connect it to the vehicle shop compressed air supply (max. 8 bar / 116 psi) to locate possible leaks faster.</p> <p>The pressure hose from the solenoid valve to fan has no kinks or leaks → see 1.1.4</p> <p>→ In the case of leaks in the hose, the hose needs to be replaced.</p> <p>→ When the air intake assembly on the fan is leaking, an appropriate seal kit must be ordered.</p>

↳ **1.1.4 Mechanical failure.**

If all the above conditions are met and the blades do not rotate, then the trouble is a mechanical error. The fan must be sent to the manufacturer for testing.

2 Blades do not return from the cleaning position to the cooling mode

→ **2.1** Fan speed is too high

→ **2.1.1** Reduce the speed.

↳ **2.1.2** Install more springs if possible.

Additional springs increase the release force. The fan must be sent to the manufacturer.

↳ **2.2** Fan cannot vent anymore

→ **2.2.1** Check the pressure hose.

The pressure hose from the solenoid valve to fan has no kinks or pinched positions
→ see 2.2.2

↳ **2.2.2** Check the functioning of the solenoid valve.

If necessary, connect external power supply.
(Please note: voltage 12 V or 24 V only)

Solenoid valve switches (soft clicking)
→ see 2.2.3

→ If the solenoid valve does not switch, replace the valve.

↳ **2.2.3** Mechanical failure

If the fan with hose disconnected does not turn back in the idle state, there is a mechanical failure. The fan must be sent to the manufacturer for testing.

